

*Getac*

E100

USER'S MANUAL

Rugged Mobile Computing Solutions

Nov. 2009

**TRADEMARKS**

All brand and product names are trademarks or registered trademarks of their respective companies.

**NOTE**

The information in this manual is subject to change without notice.

# Table of Contents

<b>Chapter 1</b>	<b>Getting Started .....</b>	<b>1-1</b>
	Getting the Tablet PC Running.....	1-2
	Unpacking .....	1-2
	Connecting to AC Power .....	1-3
	Using the Hand Strap .....	1-6
	Turning On and Off the Tablet PC .....	1-7
	Taking a Look at the Tablet PC.....	1-8
	Front Components.....	1-8
	Rear Components .....	1-10
	Right-Side Components.....	1-11
	Left-Side Components .....	1-11
	Top Components .....	1-12
	Bottom Components .....	1-13
<b>Chapter 2</b>	<b>Operating Your Tablet PC.....</b>	<b>2-1</b>
	Starting and Stopping the Tablet PC.....	2-2
	Starting the Tablet PC .....	2-2
	Stopping the Tablet PC .....	2-2
	Using the Keypad.....	2-4
	Numeric Keypad with Secondary Functions .....	2-4
	Cursor-Control Keys with Secondary Functions.....	2-5
	Using the On-screen Keyboard .....	2-6
	Using the Touchscreen Pen .....	2-7
	Using the Quick Buttons.....	2-9
	Using the Video Features .....	2-10
	Configuring the Display Modes.....	2-10
	Using the Audio Features.....	2-11

	Connecting Audio Devices .....	2-12
	Using the Communication Features .....	2-13
	Using the LAN .....	2-13
	Using the Wireless LAN .....	2-13
	Using the <i>Bluetooth</i> <sup>®</sup> Wireless Feature.....	2-16
	Using the GPS (Optional) .....	2-19
	Using the 3G Feature (Optional) .....	2-20
<b>Chapter 3</b>	<b>Managing Power .....</b>	<b>3-1</b>
	AC Adapter .....	3-2
	Battery Pack.....	3-3
	Charging the Battery Pack .....	3-3
	Initializing the Battery Pack.....	3-4
	Checking the Battery Level .....	3-4
	Replacing the Battery Pack .....	3-5
	Battery Low Signals and Actions .....	3-7
	Power Management .....	3-8
	Hibernation.....	3-9
	Power-Saving Tips.....	3-10
<b>Chapter 4</b>	<b>Expanding Your Tablet PC .....</b>	<b>4-1</b>
	Connecting a USB Device .....	4-2
	Using Smart Cards.....	4-3
	Inserting and Removing a Smart Card .....	4-3
	Using PC Cards (Optional) .....	4-4
	Inserting and Removing a PC Card.....	4-4
	Using the Docking Station .....	4-6
<b>Chapter 5</b>	<b>Using BIOS Setup and System Recovery.....</b>	<b>5-1</b>
	BIOS Setup .....	5-2
	When to Use BIOS Setup .....	5-2
	Information Menu .....	5-4
	Main Menu.....	5-5
	Advanced Menu.....	5-6
	Security Menu .....	5-7

	Boot Menu .....	5-8
	Exit Menu .....	5-9
	System Recovery .....	5-10
<b>Chapter 6</b>	<b>Using Special Utilities .....</b>	<b>6-1</b>
	Using TPM (Trusted Platform Module) .....	6-2
	Using the OSD Control Panel .....	6-3
	Quick Button Setup Utility .....	6-7
	Using the G-Manager Utility .....	6-10
	Starting G-Manager .....	6-10
	System Tab .....	6-11
	Battery Tab .....	6-12
	Light Sensor Tab .....	6-15
	ECO Tab .....	6-16
	Ignition Tab .....	6-18
	Monitoring Tab .....	6-19
	Antenna Tab .....	6-21
	GPS Status Tab .....	6-22
<b>Chapter 7</b>	<b>Caring for the Tablet PC .....</b>	<b>7-1</b>
	Protecting the Tablet PC .....	7-2
	Using the Cable Lock .....	7-2
	Taking Care of the Tablet PC .....	7-3
	Location Guidelines .....	7-3
	General Guidelines .....	7-3
	Cleaning Guidelines .....	7-4
	Battery Pack Guidelines .....	7-4
	Touchscreen Guidelines .....	7-5
	When Traveling .....	7-7
<b>Chapter 8</b>	<b>Troubleshooting .....</b>	<b>8-1</b>
	Preliminary Checklist .....	8-2
	Solving Common Problems .....	8-3
	Battery Problems .....	8-3
	<i>Bluetooth</i> Wireless Transmission Problems .....	8-3

Display Problems.....	8-4
Hardware Device Problems.....	8-4
Hard Disk Drive Problems.....	8-5
LAN Problems.....	8-5
Wireless LAN Problems.....	8-5
PC Card Problems (Optional) .....	8-7
Power Management Problems .....	8-7
Software Problems .....	8-8
Sound Problems .....	8-8
Startup Problems .....	8-9
Other Problems.....	8-9
Resetting the Tablet PC.....	8-10

**Appendix A Specifications..... A-1**

**Appendix B Regulatory Information ..... B-1**

On the Use of the System.....	B-2
Class B Regulations.....	B-2
Safety Notices .....	B-3
On the Use of the RF Device .....	B-6
USA and Canada Safety Requirements and Notices .....	B-6
European Union CE Marking and Compliance Notices....	B-9

# Chapter 1

## *Getting Started*

Congratulations on purchasing this rugged tablet PC.

This chapter first tells you step by step how to get the tablet PC up and running. Then, you will find a section briefly introducing the external components of the tablet PC.

# Getting the Tablet PC Running

This section guides you through the procedures for getting the tablet PC ready for operation.

## Unpacking

After unpacking the shipping carton, you should find these standard items:

- Notebook tablet PC
- Accessories:
  - AC adapter
  - AC power cord
  - Hand strap
  - Screen protector film (already attached to the screen)
  - Touchscreen pen

Inspect all the items. If any item is damaged or missing, notify your dealer immediately.

Keep the shipping carton and packing materials in case you need to ship or store the tablet PC in the future.



# Connecting to AC Power

The tablet PC operates either on the external AC power or internal battery power. It is suggested that you use AC power when you start up the tablet PC for the very first time.

**CAUTION:** Use only the AC adapter included with your tablet PC. Using other AC adapters may damage the tablet PC.

1. Make sure that the tablet PC is turned off.
2. Place the tablet PC upside down.
3. Lift the latch handle of the battery cover and turn it counterclockwise to the unlock position. Then, detach the cover from the tablet PC.

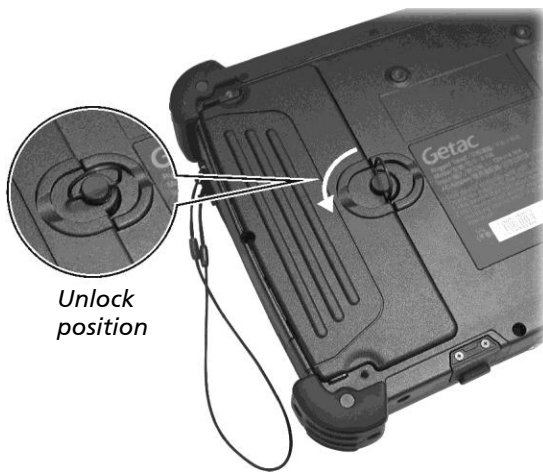

4. Fit the battery pack into place (❶). Tightening the two screws (❷) is optional. The lack of the screws will not affect the rugged and waterproof feature of the tablet PC.

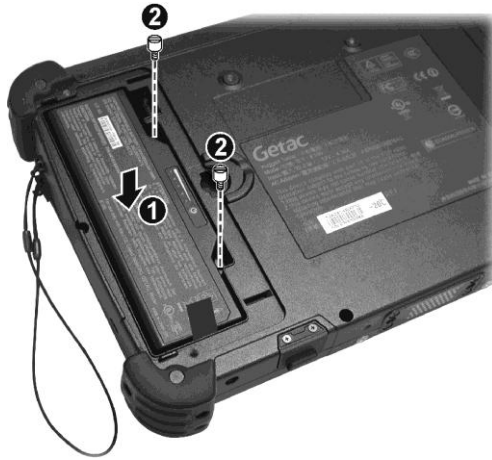

5. Replace the battery cover and turn the latch clockwise to the lock position.

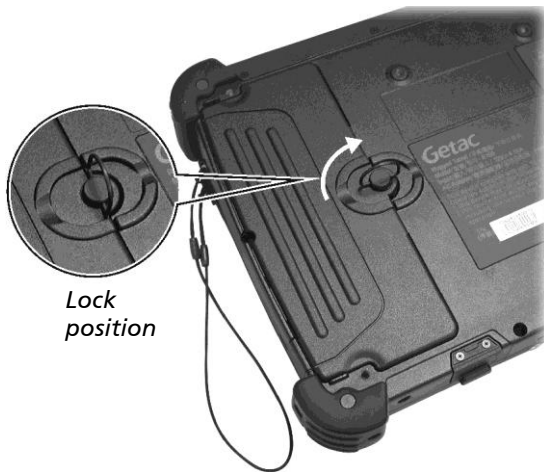

6. Plug the DC cord of the AC adapter to the power connector (  ) of the tablet PC ( **1** ). Plug the female end of the AC power cord to the AC adapter and the male end to an electrical outlet ( **2** ).

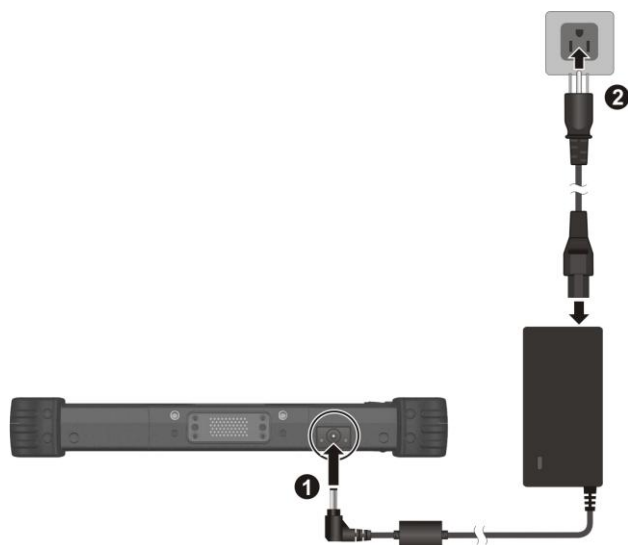

7. Power is being supplied from the electrical outlet to the AC adapter and onto your tablet PC. Now, you are ready to turn on the tablet PC.
8. When the AC adapter is connected, it also charges the battery pack. The Battery Charge Indicator (  ) on the tablet PC glows amber to indicate that charging is in progress. When the battery is fully charged, the Battery Charge Indicator glows green. (For information on using battery power, see Chapter 3.)

### CAUTION:

- When you disconnect the AC adapter, disconnect from the electrical outlet first and then from the tablet PC. A reverse procedure may damage the AC adapter or the tablet PC.
- When unplugging the connector, always hold the plug head. Never pull on the cord.

# Using the Hand Strap

Align the four hooks of the hand strap with the four corresponding holes on the tablet PC and tighten the screws.



The hand strap allows you to firmly hold the tablet PC by inserting your hand through the hand strap.



# Turning On and Off the Tablet PC

## Turning On

1. Make sure that the tablet PC is connected to AC power or the battery has power.
2. Press the power button (  ).



3. Each time the tablet PC is turned on, it performs a Power-On Self Test (POST), and the operating system Windows XP Tablet PC edition should start (may support Windows Vista Business and Ultimate in the future).

## Turning Off

To turn off the tablet PC power, use the “Shut Down” command of your operating system.

**NOTE:** There are other ways you can stop the tablet PC so that you will be back to where you left off when you next turn on the tablet PC. (See “Stopping the Tablet PC” in Chapter 2 for information.)

**CAUTION:** If you have to turn the tablet PC on again immediately after turning it off, wait for at least five seconds. Turning the tablet PC off and on rapidly can damage it.

# Taking a Look at the Tablet PC



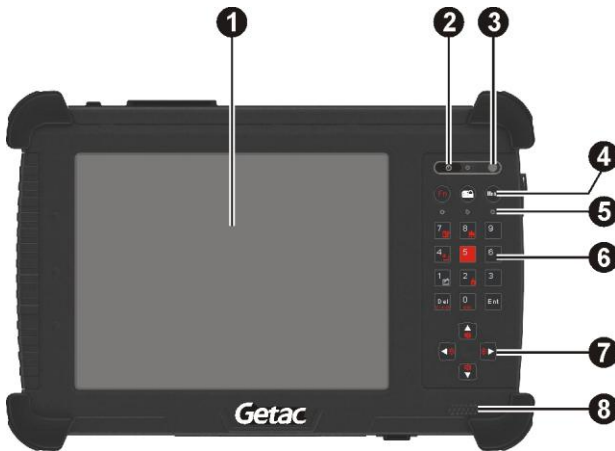

**NOTE:** Depending on the model you purchased, the appearance of your tablet PC may not be exactly the same as those shown in this manual.

**CAUTION:** When not using a connector, make sure that the connector cover is completely closed to ensure the waterproof integrity of the tablet PC.

## Front Components



Ref	Component	Description	See Also
❶	Touchscreen	Displays and receives information for the tablet PC.	P. 2-7
❷	Power Button 🔌	Turns the tablet PC power ON and OFF. The LED lights green when tablet PC is on.	P. 1-7
❸	Light Sensor	Adjusts the LCD brightness automatically based on your tablet PC's surrounding lighting condition.	

Ref	Component	Description	See Also
④	<b>Quick Buttons</b>		
	<b>Fn</b>	Toggles the <b>Fn</b> keylock ON and OFF.	P. 2-9
		Toggles the keypad lock ON and OFF by pressing for three seconds to prevent accidental pressing of keypad during transport.	P. 2-9
	<b>Menu</b>	Toggles the “OSD Control Panel” utility ON and OFF.	P. 2-9
⑤	<b>Indicators</b>	Show the current status of the tablet PC's devices.	
	<b>WLAN/WWAN</b> 	Lights green when WLAN is on.	P. 2-14
		Lights amber when WWAN is on.	
	<b>Battery Charge</b> 	Lights green when the battery is fully charged.	P. 3-3
		Lights amber when the battery is being charged.	
		Blinks red when the battery's capacity is below 10%.	
<b>Hard Disk Drive / Heater (option)</b> 	Lights green when hard disk drive is in use.		
	Lights red when optional heater is on (temperature is lower than 5°C when booting your tablet PC).		
⑥	<b>Numeric Keypad</b>	Facilitates entering of numbers, also includes the <b>Del</b> (Delete) and <b>Ent</b> (Enter) keys. When <b>Fn</b> keylock is on, the alternative function of a key is activated. The alternative functions are identified by the color of orange on the keytop.	P. 2-4

Ref	Component	Description	See Also
7	Cursor-control Keys	Serves as the UP / DOWN / LEFT / RIGHT arrow keys (except pointer on screen). When Fn keylock is on, the alternative function of a key is activated. The alternative functions are identified by the color of orange on the keytop.	P. 2-4
8	Speaker	Sends out sound and voice from your tablet PC.	P. 2-11

## Rear Components

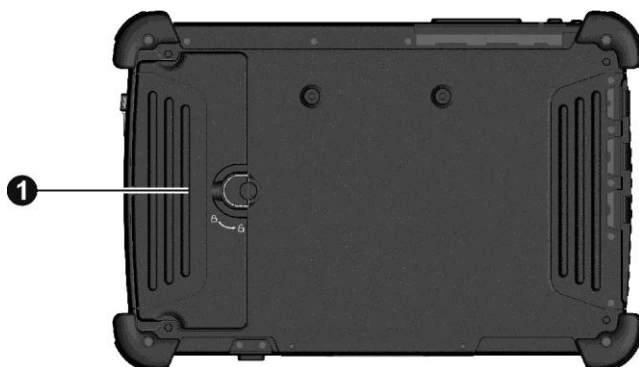

Ref	Component	Description	See Also
1	Battery Pack / 3G SIM Card Slot Compartment	Inside is the battery pack that supplies power to your tablet PC when external power is not connected.	P. 3-3
		Contains the 3G SIM card slot (optional).	P. 2-20



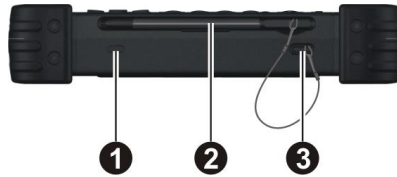

## Right-Side Components

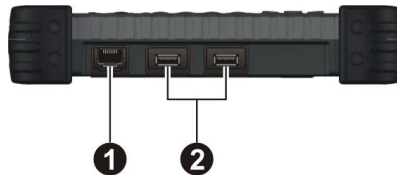

Ref	Component	Description	See Also
❶	Kensington Lock 	Locks the tablet PC to a stationary object for security.	P. 7-2
❷	Touchscreen Pen	Serves as the input device by tapping on the touch screen to make selections and enter information.	P. 2-7
❸	Tether Hole	Touchscreen pen tethered to this hole.	

## Left-Side Components



Ref	Component	Description	See Also
❶	RJ-45 Connector 	Connects the LAN cable.	P. 2-13
❷	USB Ports 	Each of the two ports connects a USB device, such as a USB flash disk, printer, digital camera, joystick, and more.	P. 4-2

# Top Components



Ref	Component	Description	See Also
❶	Smart Card Reader	Accepts a smart card for additional security feature.	P. 4-3
❷	PC Card Slot (optional)	Accepts a PC card for additional functions.	P. 4-4
		There is no PCMCIA slot if your model comes with the 3G module.	
❸	Audio Output Connector 	Connects a set of headphones, external speakers with amplifier, or an audio recording device.	P. 2-11

# Bottom Components

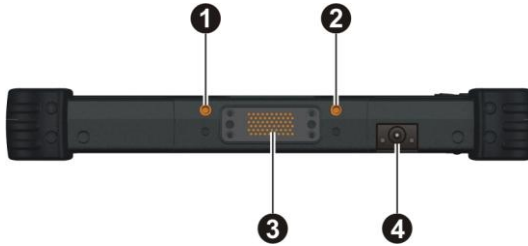

Ref	Component	Description	See Also
①	<b>3G Pass-through Connector (option)</b>	Connects to the optional antenna for wireless WAN (wide area network) 3G transmission. <b>NOTE:</b> Must be connected via a docking station.	P. 2-20
②	<b>GPS Pass-through Connector (option)</b>	Connects to the optional antenna for GPS receiver.	P. 2-19
③	<b>Docking Connector</b>	Connects to a docking station.	P. 4-6
④	<b>Power Connector</b> ==	Connects the AC adapter.	P. 1-3



## Chapter 2

# *Operating Your Tablet PC*

This chapter provides information about the use of the tablet PC.

If you are new to tablet PCs, reading this chapter will help you learn the operating basics. If you are already a computer user, you may choose to read only the parts containing information unique to your tablet PC.

# Starting and Stopping the Tablet PC

There are a number of ways to start and stop the tablet PC.

## Starting the Tablet PC

You always start the tablet PC using the power button.

A tablet PC starts up with an operating system (OS) existing on the storage device such as the hard disk. The tablet PC will automatically load the OS after you turn it on. This process is called booting.

**NOTE:** An operating system is the platform for all your software application programs to run on. Your tablet PC uses the Microsoft Windows XP Tablet PC edition operating system.

## Stopping the Tablet PC

When you finish a working session, you can stop the tablet PC by turning off the power or leaving the tablet PC in Standby or Hibernation mode:

To stop in this mode...	Do this...	To start up or resume again
Off	Follow the shutdown procedure of your operating system. This can prevent loss of unsaved data or damage to your software programs.  If the system is locked up because of hardware or software problems, press the power button to turn off the tablet PC.	Press the power button.
Standby	Depending on your settings in Windows, you can place the tablet PC in Standby mode by pressing the power button.	Press the power button.

To stop in this mode...	Do this...	To start up or resume again
Hibernation	Depending on your settings in Windows, you can place the tablet PC in Hibernation mode by pressing the power button.	Press the power button.

If you choose to stop in Standby or Hibernation mode, you can return to where you left off the next time you start up the tablet PC. (See “Power Management” in Chapter 3 for more information.)

# Using the Keypad

Your keypad can be divided into two major categories:

- Numeric, Delete (Del), and Enter (Ent) keys
- Cursor-control keys



**NOTE:** To use the keypad during poor lighting conditions, turn the keypad backlight ON by pressing the **Fn** button, then press the “8” () button.

## Numeric Keypad with Secondary Functions

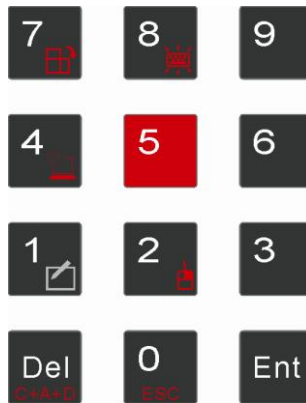

The 12-key numeric keypad with Delete and Enter keys is shown next:



When the **Fn** keylock is ON ( icon appears on the system tray), you can use the following secondary functions with orange color on top of each button.

-  switches between landscape and portrait LCD display.
-  switches the keypad backlight ON and OFF.
-  switches the touchscreen OFF and ON.





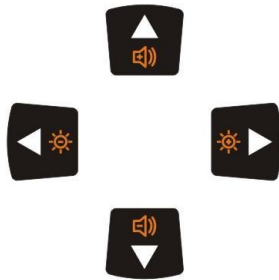

-  switches the sunlight-readable mode ON and OFF.
-  serves as the mouse right-click button.
- **C+A+D** serves as the **Ctrl+Alt+Del** key combination.
- **ESC** serves as the **Escape** key.

## Cursor-Control Keys with Secondary Functions

The word “cursor” refers to the indicator on the screen (except for pointer on screen) that lets you know exactly where on your screen anything you type will appear. It can take the form of a vertical or horizontal line, a block, or one of many other shapes.



When the **Fn** keylock is ON (  icon appears on the system tray), you can use the following secondary functions with orange color on top of each button.

-  increase the sound volume of your tablet PC.
-  decrease the sound volume of your tablet PC.
-  increase the brightness of LCD display.
-  decrease the brightness of LCD display.

# Using the On-screen Keyboard

Use the on-screen keyboard to enter text and perform various keyboard functions.

1. Click the on-screen keyboard icon (  ) located on the Windows system tray and the software keyboard will appear onscreen.

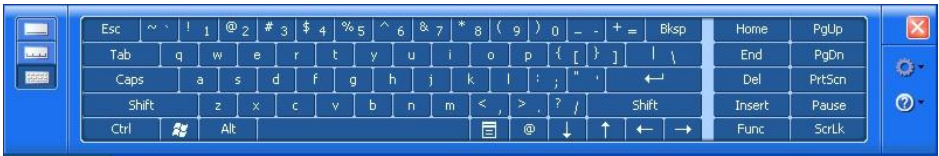

2. Tap the characters on the on-screen keyboard with the touchscreen pen.

**NOTE:** To protect the LCD display, use the touchscreen pen on your touchscreen.

# Using the Touchscreen Pen

**NOTE:** The touchscreen function is not available when running the BIOS Setup program or when using the full screen in DOS mode.

**CAUTION:** Do not use a sharp object such as a ballpoint pen or pencil on the touchscreen. Doing so may damage the touchscreen surface. Use your finger or the included touchscreen pen. A screen protector film has been attached to the screen before shipment. The film is a consumable, which will be worn out after a period of use (6 months in average). You can purchase a new one when replacement is required.

The touchscreen is a touch-sensitive device that allows you to easily use the tablet PC without a mouse or touchpad to communicate with the tablet PC by controlling the location of the pointer on the screen and making selection with the buttons.





Here are some common terms that you should know when using the touchscreen:

Term	Action
Click/Point	Tap gently on the touchscreen.
Double-click	Tap twice on the touchscreen rapidly.
Drag and drop	Press lightly on the touchscreen and move your finger until you reach your destination (drag). Finally, release your finger (drop) when you finish dragging your selection to the destination. The object will drop into the new location.

# Using the Quick Buttons







Located on top of the keypad are three quick buttons:

- **Fn** button toggles the **Fn** keylock ON and OFF (  icon appears on the system tray when ON). You can use the secondary functions of keypad buttons with orange color on top of each button (as described in the “Using the Keypad” section earlier in this chapter).
-  button toggles the keypad lock ON and OFF. Press the button to turn on or press continuously for more than three seconds to turn off. This would prevent accidental pressing of the keypad buttons during transport.
- **Menu** button toggles the OSD Control Panel utility ON and OFF. Upon pressing it the following screen appears (see chapter 6 for more details).



# Using the Video Features

The video subsystem of your tablet PC features:

- 8.4-inch wide TFT (Thin-Film Transistor) color LCD with SVGA transmissive display
- Toggle display between landscape view and portrait view using the LCD rotate button 
- Built-in light sensor to automatically adjust the LCD brightness
- Manually adjust the display brightness using the LCD brightness up () and down () buttons
- Power Management
- Sunlight-readable LCD display using the sunlight-readable mode button  (option)

## Configuring the Display Modes

Your tablet PC has been set to a default resolution and number of colors before shipment. You can view and change display settings through your operating system. See your operating system documentation or online help for specific information.

# Using the Audio Features

The audio subsystem of your tablet PC features:

- High density audio codec
- Manually adjust the sound volume using the sound volume up (🔊) and down (🔊) buttons
- Audio-out connector (🎧) (1)
- Integrated speaker (2)



Ways of playing and recording sound vary with the operating system used. See your operating system documentation or online help for specific information.

# Connecting Audio Devices

For higher audio quality, you can send sound through external audio devices such as speakers, headphones, or earphone set using the audio-out connector.



**NOTE:**



- After connecting an external audio device, make sure that you specify the use of the correct audio device in Windows.
- When using the external speakers/headphones, you cannot use the internal one.



# Using the Communication Features

## Using the LAN

The internal 10/100/1000Base-T LAN (Local Area Network) module allows you to connect your tablet PC to a network. It supports data transfer rate up to 1000 Mbps.

To connect the network cable to the LAN module, connect one end of the LAN cable to the RJ-45 connector (   ) on the tablet PC and the other end to the network hub.

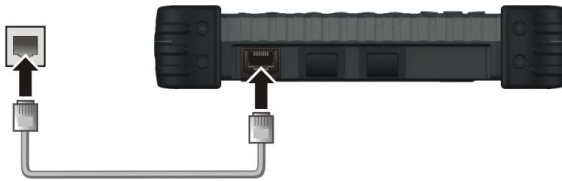

## Using the Wireless LAN

The WLAN features include:

- Peer-to-Peer (Ad-Hoc) and Access Point (Infrastructure) modes support
- WEP (Wired Equivalent Privacy) 64/128-bit data encryption
- IEEE 802.11b/g standard compliance

Technology	802.11b	802.11g
Stated Maximum Throughput (Mbps)	11	54
Data Rates (Mbps)	11, 5.5, 2, 1	54, 36, 18, 9
Band (GHz)	2.412 ~ 2.462	2.4
Modulation Technology	DSSS (Direct Sequence Spread Spectrum)	OFDM (Orthogonal Frequency Division Multiplexing)

**NOTE:** 802.11g mode is backward compatible with 802.11b mode.

## Turning Off/On the WLAN Radio

**NOTE:** The FAA (Federal Aviation Agency) has deemed it unsafe to operate wireless devices in aircraft as this may interfere with flight safety. Remember to turn off wireless LAN when using your tablet PC in the airplane.

1. Press the **Menu** button on your tablet PC to start up the OSD Control Panel utility.
2. Click the RF button to switch the WLAN radio on/off, indicated by the WLAN indicator (  ) glowing in green when on.

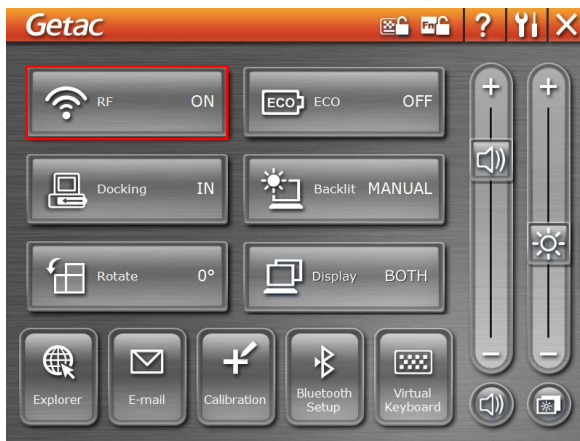

If you need to temporarily turn off the radio, click the RF button. To resume network connection, click the RF button again. Upon restarting your system, wireless LAN radio would be on even if you turned it off before system shutdown.

It takes approximately 30 seconds for your tablet PC to make a successful WLAN connection and approximately 10 seconds to disconnect.

# Connecting to a Wireless Network

To connect to a wireless network:

1. Make sure that the wireless LAN radio is “on” indicated by the wireless LAN indicator (📶) glowing in green.
2. Double-click the **Wireless Network Connection** icon  located on your Windows system tray. If any wireless network is detected, the following window appears on screen.

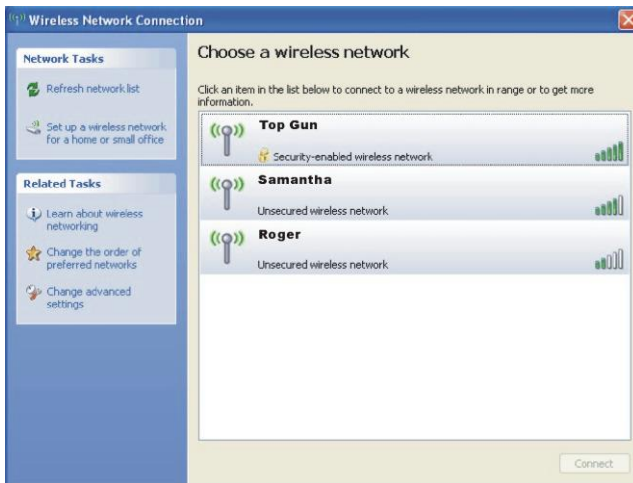



3. Click to select a wireless network to connect to, and then click **Connect**.
4. Depending on the settings, you may be asked to enter a WEP key (refer to your Windows online help for more information on setting a wireless network connection).

# Using the *Bluetooth*<sup>®</sup> Wireless Feature

Depending on your model, your tablet PC may incorporate the Bluetooth capability for short-range (about 10 meters) wireless communications between devices without requiring a cable connection.

With Bluetooth, data can be transmitted through walls, pockets and briefcases as long as two devices are within range. By default, your tablet PC's Bluetooth feature is active (always ON) upon booting your tablet PC and is in the general discoverable and pairable mode.

The status of the Bluetooth connection is indicated by the Bluetooth icon located in the system tray in the lower-right part of the screen.

Status	Icon
On	 (blue with white logo).
Connected	 (blue with green logo)

You can use the Bluetooth Utility to configure Bluetooth connection settings and transfer files.

## Connecting to Another *Bluetooth* Device

1. Make sure that the target *Bluetooth* device is turned on, discoverable and within close range. (See the documentation that came with the *Bluetooth* device.)
2. Right-click (press lightly until a pop-up menu appears) the  icon, and then click **Add New Connection**.

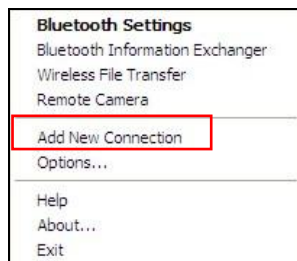

3. The **Add New Connection Wizard** window appears. Select **Express Mode (Recommended)**, and then click **Next**.



4. Select the device to connect to and click **Next**.



5. Depending on the type of *Bluetooth* device that you want to connect to, you will need to enter the pertinent information.

## Sending a File

1. Make sure that the target *Bluetooth* device is turned on, discoverable and within close range. (See the documentation that came with the *Bluetooth* device.)
2. Right-click the  icon, and then click **Wireless File Transfer**.



3. In the **Wireless File Transfer** window, click **Add** to browse for the file to send.
4. Click the target device from the list, and then click **Send** to start the transfer procedure.



## Using the GPS (Optional)

Depending on the model you purchased, your tablet PC may have the GPS receiver module built in.

GPS (Global Positioning System) is a constellation of 24 well-spaced satellites that orbit the Earth and make it possible for devices enabled with GPS receivers to pinpoint their location.

You need to install third-party GPS navigation software to take advantage of the GPS feature.

Refer to chapter 6 on using the GPS feature.

## Using the 3G Feature (Optional)

3G is the third generation of mobile phone standards and technology, after 2G. It is based on the International Telecommunication Union (ITU) family of standards under the International Mobile Telecommunications programme, "IMT-2000". Services include wide-area wireless voice telephony and broadband wireless data, all in a mobile environment.

Unlike IEEE 802.11 networks, 3G networks are *wide area cellular telephone networks* which evolved to incorporate high-speed internet access and video telephony. IEEE 802.11 networks are short range, high-bandwidth networks primarily developed for data.

To use the 3G feature on your computer, you need to subscribe to 3G service and install the 3G SIM card from your service provider, network operator, or other vendor.

To install the SIM card, follow these steps:

1. Make sure that the tablet PC is not turned on or connected to AC power.
2. Place the tablet PC upside down.
3. Lift the latch handle of the battery cover and turn it counterclockwise to the unlock position. Then, detach the cover from the tablet PC.

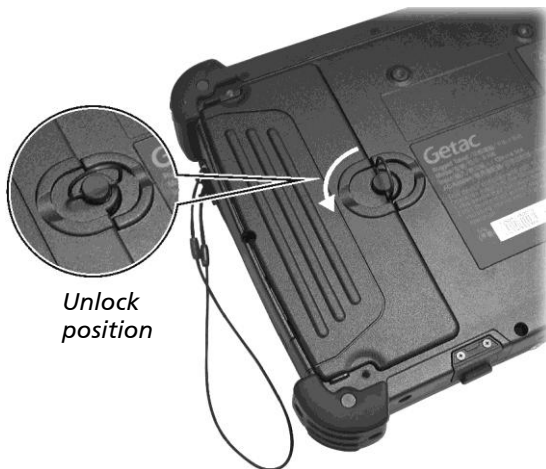



4. Remove the two screws if existing (1). Pull on the ribbon strip to lift the battery pack off the computer (2).

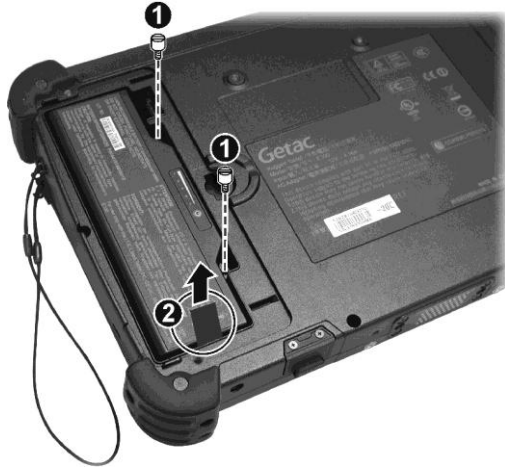

5. Locate the SIM card slot and push the SIM card into the slot. Make sure the beveled corner on the SIM card is facing towards the tablet PC and that the golden contact area on the card is facing downwards.



To remove the SIM card, just push in (❶) the SIM card to pop-out (❷) and remove the card.



6. Fit the battery pack into place and secure with two screws.
7. Replace the battery cover and turn the latch clockwise to the lock position.

**WARNING:** Keep all SIM cards out of the reach of small children. For availability and information on using SIM card services, contact your SIM card vendor. This may be the service provider, network operator, or other vendor.

# Chapter 3

## *Managing Power*

Your tablet PC operates either on external AC power or on internal battery power.

This chapter tells you how you can effectively manage power. To maintain optimal battery performance, it is important that you use the battery in the proper way.

# AC Adapter

## CAUTION:

- The AC adapter is designed for use with your tablet PC only. Connecting the AC adapter to another device can damage the adapter.
- The AC power cord supplied with your tablet PC is for use in the country where you purchased your tablet PC. If you plan to go overseas with the tablet PC, consult your dealer for the appropriate power cord.
- When you disconnect the AC adapter, disconnect from the electrical outlet first and then from the tablet PC. A reverse procedure may damage the AC adapter or tablet PC.
- When unplugging the connector, always hold the plug head. Never pull on the cord.



The AC adapter serves as a converter from AC (Alternating Current) to DC (Direct Current) power because your tablet PC runs on DC power, but an electrical outlet usually provides AC power. It also charges the battery pack when connected to AC power.

The adapter operates on any voltage in the range of 100~240 V AC.

# Battery Pack

The battery pack is the internal power source for the tablet PC. It is rechargeable using the AC adapter.

The operating time of a fully charged battery pack depends on how you are using the tablet PC. When your applications often access peripherals, you will experience a shorter operating time.

**NOTE:** Care and maintenance information for the battery is provided in the “Battery Pack Guidelines” section in Chapter 7.

## Charging the Battery Pack

**NOTE:**

- Charging will not start if the battery’s temperature is below 0 °C (32 °F). It is also recommended not to charge the battery when temperature is above 35 °C (95 °F).
- To prevent damage, the charging process may stop and the Battery Charge Indicator flashes red when the environmental temperature gets above 55 °C (131 °F).
- During charging, do not disconnect the AC adapter before the battery has been fully charged; otherwise you will get a prematurely charged battery.

To charge the battery pack, connect the AC adapter to the tablet PC and an electrical outlet. The Battery Charge Indicator () on the tablet PC glows amber to indicate that charging is in progress. You are advised to keep the tablet PC power off while the battery is being charged. When the battery is fully charged, the Battery Charge Indicator glows green.

It takes approximately 3 hours to fully charge the Li-Ion battery pack at a room temperature of 25 °C (may need a longer charging time at lower temperatures).

**CAUTION:** After the tablet PC has been fully recharged, do not immediately disconnect and reconnect the AC adapter to charge it again. Doing so may damage the battery.

**NOTE:** The battery level may automatically lessen due to the self-discharge process (0.21% per day), even when the battery pack is fully charged (100%). This happens no matter if the battery pack is installed in the tablet PC.

## Initializing the Battery Pack

You need to initialize a new battery pack before using it for the first time or when the actual operating time of a battery pack is much less than expected.



Initializing is the process of fully charging, discharging, and then charging. It can take several hours.

1. Make sure that the tablet PC power is turned off. Connect the AC adapter to fully charge the battery pack.
2. After the battery pack is fully charged, turn on the tablet PC. Press the **Ent** key when the prompt appears on the screen during system startup. The prompt shows up on the screen for only a few seconds. You must press the **Ent** key quickly.
3. A small window appears, select **Launch System Setup** to invoke the program.
4. Disconnect the AC adapter and leave the tablet PC on until the battery is fully discharged. The tablet PC will shut down automatically.
5. Connect the AC adapter to fully charge the battery pack.

## Checking the Battery Level

**NOTE:** Any battery level indication is an estimated result. The actual operating time can be different from the estimated time, depending on how you are using the tablet PC.

### By Operating System

You can check the approximate battery level using the battery meter function of the operating system. To read the battery level in Windows, click the  icon on the taskbar. (Click the  icon if the tablet PC is using AC power.)

## By Gas Gauge

On the exterior side of the battery pack is a gas gauge for displaying the estimated battery charge. When the battery pack is not installed in the tablet PC and you want to know the battery charge, you can press the switch with a pointed device to see the corresponding value of indicator segment that light green. The value of the corresponding green segment indicates the relative percentage of the battery charge. The battery pack is fully discharged when you see no segment glowing green.

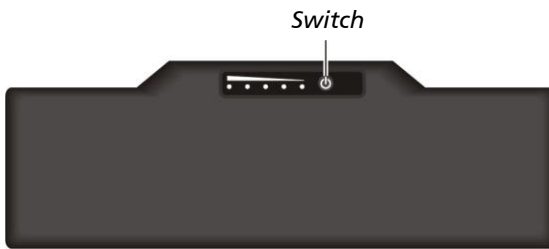

## Replacing the Battery Pack

### CAUTION:

- There is danger of explosion if the battery is incorrectly replaced. Replace the battery only with the tablet PC manufacturer's optional battery packs. Discard used batteries according to the dealer's instructions.
- Do not attempt to disassemble the battery pack.

If you often rely on battery power for a long period of time while traveling, you may consider the purchase of an additional battery pack from your dealer and keep it with you in a fully charged state as a backup.

To replace the battery pack, follow these steps:

1. Make sure that the tablet PC is not turned on or connected to AC power.
2. Place the tablet PC upside down.

3. Lift the latch handle of the battery cover and turn it counterclockwise to the unlock position. Then, detach the cover from the tablet PC.

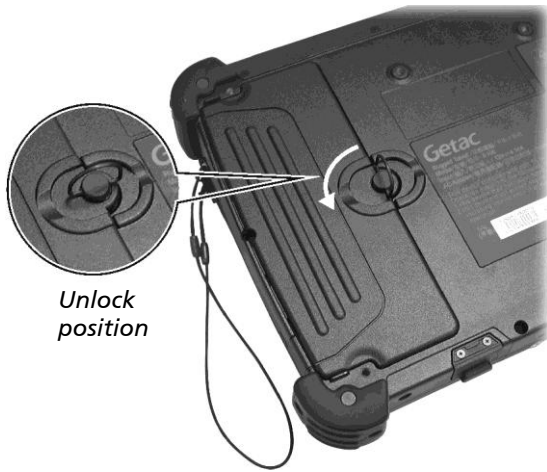

4. Remove the two screws if existing (❶). Pull on the ribbon strip to lift the battery pack off the computer (❷).

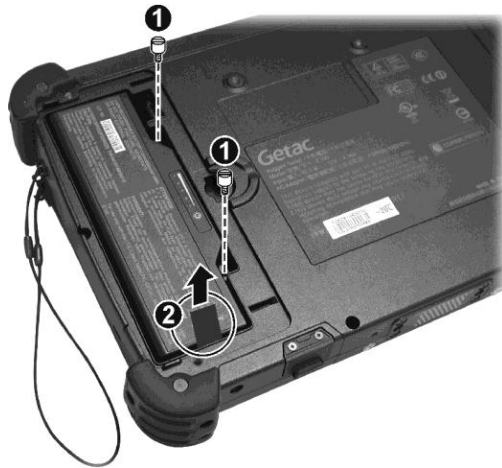

5. Fit another battery pack into place.



6. Replace the battery cover and turn the latch clockwise to the lock position.

## Battery Low Signals and Actions

Battery Low occurs when the battery has approximately 10% (Windows default setting) of its charge remaining. The tablet PC's Battery Charge Indicator (  ) blinks red to alert you to take actions.

**NOTE:** You can set up your threshold and signals of Battery Low under Windows.

Immediately save your data upon Battery Low. The remaining operating time depends on how you are using the tablet PC. If you are using the audio subsystem, hard or USB flash disk, the battery might run out of charge very quickly.

Always respond to Battery Low by placing your tablet PC on the Standby or Hibernation mode, turning off the tablet PC, or connecting the AC adapter. If you do not take any action, the tablet PC will automatically hibernate and turn off.

**CAUTION:** If you fail to save your data when the battery completely runs out of charge, then you lose your data.

# Power Management

Your tablet PC supports ACPI (Advanced Configuration and Power Interface) for power management. The power management feature allows you to reduce the power consumption for energy saving.

With an ACPI-compliant operating system such as Windows, power supply to different tablet PC components is controlled on an as-needed basis. This allows maximum power conservation and performance at the same time.

In general, Windows' power management works in this way:

What...	When...
Power to the hard disk is turned off	When the hard disk has been idle for a set period.
Power to the display is turned off	When the display has been idle for a set period.
The tablet PC enters the Standby mode. The hard disk and display are turned off and the entire system consumes less power.	When the entire system has been idle for a set period.
	When you press the power button. *
The tablet PC enters the Hibernation mode. (See the next subsection for more information.)	When the entire system has been idle for a set period.
	When you press the power button. *

\* Depends on your settings in Windows.

For detailed information on power management, see Windows' Help.

# Hibernation

**NOTE:** Make sure that the hibernation feature is enabled in the **Hibernate** tab of the **Power Options** Properties from the Control Panel in Windows XP.

Hibernation is a very useful feature. People frequently open many applications when they use computers. It takes some time to get all these applications open and running, and normally they all have to be closed before the computer can be turned off.

When you use the hibernation feature, you do not have to close the applications. The tablet PC stores the state of your tablet PC to a file on the hard disk and then shuts down. The next time you turn on your tablet PC, you return to exactly where you left off.

# Power-Saving Tips

Aside from enabling your tablet PC's power saving mode (see previous section), you can do your part to maximize the battery's operating time by following these suggestions.

- Do not disable Power Management.
- Decrease the LCD brightness to the lowest comfortable level.
- Shorten the length of time before Windows turn off the display.
- Many USB devices use power just by being connected. If you use a USB mouse, you can save power by disconnecting the mouse and using the optional touchscreen pen. If you use a USB flash drive, unplug it when you are not using it.
- Deactivate the Wireless LAN function if you are not using it (see Chapter 2).
- Deactivate the *Bluetooth* wireless feature if you are not using it (see Chapter 2).
- Turn off the tablet PC when you are not using it.

# Chapter 4

## *Expanding Your Tablet PC*

You can expand the capabilities of your tablet PC by connecting other peripheral devices. When using a device, be sure to read the instructions accompanying the device together with the relevant section in this chapter.

# Connecting a USB Device

Your tablet PC has two USB ports for connecting USB devices, such as a digital camera, scanner, printer, modem, and mouse.

The USB ports support transfer rates up to 12 MB/s for USB 1.1 devices and 480 MB/s for USB 2.0 devices.

To connect a USB device, simply plug the device cable to one of the USB ports (  ).

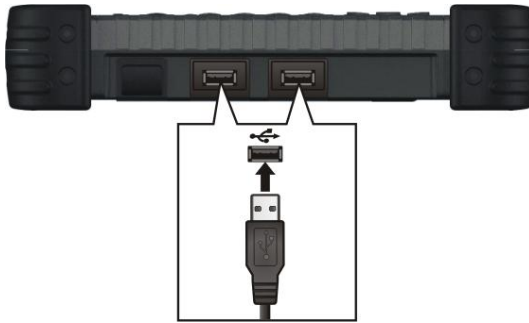

# Using Smart Cards

Your tablet PC has a smart card slot for additional security feature, providing tamper-proof storage of user and account identity. A smart card is a type of plastic card embedded with a computer chip that stores and transacts data between you (user) and the tablet PC.

You need to install third-party smart card software to take advantage of the smart card feature.

## Inserting and Removing a Smart Card

To insert a smart card:

1. Locate the smart card slot on the top of the tablet PC.
2. Slide the smart card, with its label and embedded computer chip facing up into the slot.

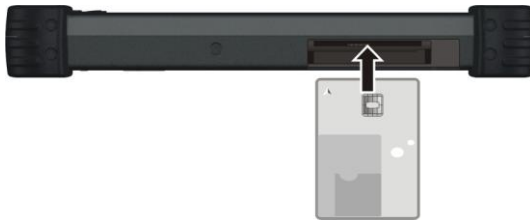

3. When a new card is seated, use the third-party smart card software to allow your tablet PC to read it.

To remove a smart card:

1. Make sure that the third-party smart card software is not accessing the smart card.
2. Pull the card out of the slot.

# Using PC Cards (Optional)

Depending on your model, your tablet PC has one PC card slot which supports type II card and CardBus specifications.

## Inserting and Removing a PC Card

### NOTE:

- Some PC cards require additional system resources. Before using such PC card, you may have to free other system resources for the PC card.
- Although some PC cards can be inserted and removed without turning off the computer, you cannot remove or install PC cards during Sleep mode.

To insert a PC card:

1. Locate the PC card slot on the top of the tablet PC.
2. Slide the PC card, with its label facing up, into the slot until the eject button pops out.

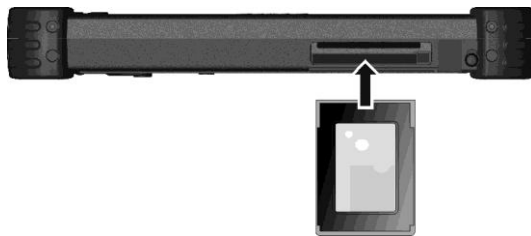

3. When a new card is seated, the tablet PC will detect it and try to install the appropriate driver. Follow the on-screen instructions to complete the process.



To remove a PC card:

1. Double-click on the **Safely Remove Hardware**  icon found on the Windows taskbar and the **Safely Remove Hardware** window appears on screen.
2. Select (highlight) the PC card from the list to disable the card.
3. Push the eject button and the card will slide out slightly.
4. Pull the card out of the slot.

# Using the Docking Station

A docking station is available as an option. This device eliminates the hassles of having you connect and disconnect the various cables when carrying your tablet PC around and allows a variety of peripherals to be connected including a headphone or microphone, etc. The docking station connects to the docking connector at the front of your tablet PC.

1. Locate the docking connector.



2. Connect your docking station to the docking connector.

For more detailed information, refer to the Operating Instructions of the docking station.

**NOTE:** Hot/warm docking and hot/warm undocking are possible with the docking connector but it is recommended that prior to undocking, press the **Menu** button and the OSD Control Panel appears. Click the **Docking** button.

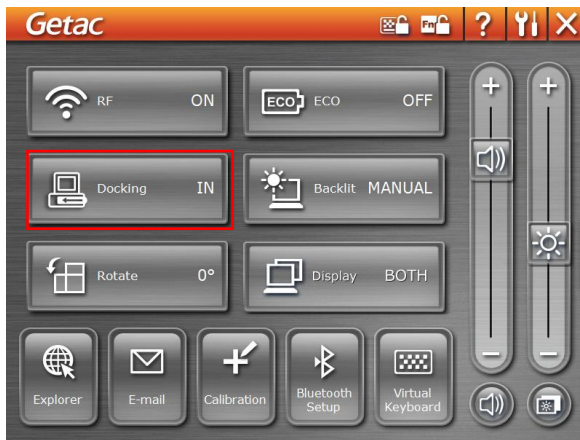

# Chapter 5

## *Using BIOS Setup and System Recovery*

BIOS Setup Utility is a program for configuring the BIOS (Basic Input/ Output System) settings of the tablet PC. BIOS is a layer of software, called firmware, that translates instructions from other layers of software into instructions that the tablet PC hardware can understand. The BIOS settings are needed by your tablet PC to identify the types of installed devices and establish special features.

System Recovery reinstalls Windows to your system and configures it to the system's factory default settings.

This chapter tells you how to use the BIOS Setup and System Recovery.

# BIOS Setup

## When to Use BIOS Setup

### When to Use

You need to run BIOS Setup Utility when:

- You see an error message on the screen requesting you to run BIOS Setup Utility.
- You want to restore the factory default BIOS settings.
- You want to modify some specific settings according to the hardware .
- You want to modify some specific settings to optimize the system performance.

### Starting BIOS Setup

#### **NOTE:**

- The BIOS Setup Utility screens shown in this chapter are for your reference only. The actual items or settings on your tablet PC may differ.
- The BIOS Setup Utility program may have been updated after the publication of this manual.
- The settings you select in your operating system might override similar settings in BIOS Setup Utility.

To run BIOS Setup utility, press the **Ent** key when the prompt appears on the screen during system startup. The prompt shows up on the screen for only a few seconds. You must press the **Ent** key quickly. A small window appears, select **Launch System Setup**. The BIOS Setup Utility main screen appears as shown next.

Information		Main	Advanced	Security	Boot	Exit
Model No.:	E100					
Serial No.:	Not Applicable					
Processor Info :	Genuine Intel(R) processor 800 MHz					
Installed System Memory :	512 MB					
IDE Channel 0 Master	[TOSHIBA MK4009GAL] 40001 MB					
BIOS Revision :	R0.53F					
EC Revision :	R0.53B					
LAN MAC Address :	00-40-D0-AE-FB-67					
IEEE 1394 GUID :	00-43-44-81-00-40-D0-01					
Operating Time :	75 Hours					
F1 Help	↑↓ Select Item	-/+ Change Values	F9 Setup Defaults			
Esc Exit	← Select Menu	Enter Select ► Sub-Menu	F10 Save and Exit			

The BIOS Setup Utility screen can be divided into four areas:

- On the top is the menu bar containing the titles of the available menus. Each menu title brings a specific menu.
- The left column of the menu displays the menu items.
- The right column of the menu provides more detailed information when a menu item is highlighted.
- The bottom of the menu provides keyboard instructions for moving around and making selections.

## Moving Around and Making Selections

You must go through two or three levels to complete the setting for an item. In most cases, there are two levels: menu title and submenu.

Use the keyboard to move around and make selections. Keyboard information can be found at the bottom of the screen. A brief description of keyboard usage is listed next:

Key	Function
←, →	Selects a menu title.
↑, ↓	Selects an item or option.
+ / -	Changes the value.
Ent	1) Brings up the sub-menu when available. 2) Opens or closes the option window when an item is selected.

**NOTE:** You can press the **F1**, **F9**, **F10**, **-/+**, and **Esc** keys by connecting a USB keyboard to your tablet PC. Make sure that the item “Legacy USB Support” under the Main menu is set at *Enabled* (default).

## Information Menu

The Information menu contains the basic configuration information of the system.

Information	Main	Advanced	Security	Boot	Exit
Model No.:	E100				
Serial No.:	Not Applicable				
Processor Info :	Genuine Intel(R) processor 800 MHz				
Installed System Memory :	512 MB				
IDE Channel 0 Master	[TOSHIBA MK4009GAL] 40001 MB				
BIOS Revision :	R0.53F				
EC Revision :	R0.53B				
LAN MAC Address :	00-40-D0-AE-FB-67				
IEEE 1394 GUID :	00-43-44-81-00-40-D0-01				
Operating Time :	75 Hours				
F1 Help	↑↓ Select Item	-/+ Change Values	F9 Setup Defaults		
Esc Exit	←→ Select Menu	Enter Select	▶ Sub-Menu	F10 Save and Exit	

# Main Menu

The Main menu contains the system time and date, as well as the USB setting of the system.

Information				Main	Advanced	Security	Boot	Exit
System Time:		[16:34:08]		Item Specific Help				
System Date:		[08/23/2007]						
Power Button Delay:		[Disabled]		<Tab>, <Shift-Tab>, or <Enter> selects field.				
Legacy USB Support:		[Enabled]						
F1 Help	↑↓ Select Item	-/+ Change Values	F9 Setup Defaults					
Esc Exit	←→ Select Menu	Enter Select ► Sub-Menu	F10 Save and Exit					

**System Time** sets the system time.

**System Date** sets the system date.

**Power Button Delay** allows you to prevent accidental pressing of the power button.

**Legacy USB Support** enables the system's support for Legacy USB device in DOS mode.

# Advanced Menu

The Advanced menu contains the advanced settings as shown next.

Information	Main	Advanced	Security	Boot	Exit
Total Graphics Memory: [64 MB] DVMT Graphics Memory: 56 MB  HDD Preheat: [Disabled]  High Temperature Protection: [Enabled]					Item Specific Help
F1 Help    ↑↓ Select Item    -/+ Change Values    F9 Setup Defaults Esc Exit   ← Select Menu    Enter Select    ▶ Sub-Menu    F10 Save and Exit					

**Total Graphics Memory** allows you to select the amount of total graphics memory (pre-allocated + fixed + DVMT) for use by the internal graphics device.

**DVMT Graphics Memory** shows the size of DVMT graphics memory.

**HDD Preheat** allows your system to automatically turn on the optional heater when temperature of the hard disk drive is lower than 5°C.

**NOTE:** The optional heater can function when your tablet PC is connected to AC power or using battery power but the preheat feature can only function when your tablet PC is connected to AC power.

**High Temperature Protection** allows you to turn off hard disk drive power to prevent damage to data when HDD temperature goes above the safe range. System will also show a warning message.



# Security Menu

The Security menu contains the TPM (Trusted Platform Module) setting. The TPM is a component on your tablet PC's mainboard that is specifically designed to enhance platform security above-and-beyond the capabilities of today's software by providing a protected space for key operations and other security critical tasks. Using both hardware and software, TPM protects encryption and signature keys at their most vulnerable stages – operations when the keys are being used unencrypted in plain-text form. TPM is specifically designed to shield unencrypted keys and platform authentication information from software-based attacks.

Information	Main	Advanced	Security	Boot	Exit
TPM Support [Enabled]				Item Specific Help	
Current TPM State: Disabled and Deactivated				Enable Trusted Platform Module support.	
Change TPM State [No Change]					
F1 Help	↑↓ Select Item	-/+ Change Values	F9 Setup Defaults		
Esc Exit	←→ Select Menu	Enter Select ▶ Sub-Menu	F10 Save and Exit		

**TPM Support** enables or disables TPM support (see chapter 6 for details).

**Current TPM State** shows the current TPM state.

**Change TPM State** allows you to select between *No Change*, *Clear*, *Deactivate & Disable*, and *Enable & Activate*.

# Boot Menu

The Boot menu sets the sequence of the devices to be searched for the operating system.

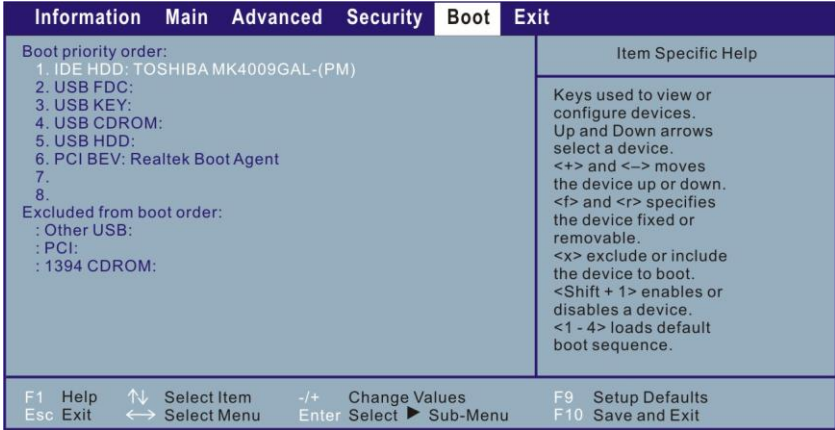

The bootable devices will be automatically detected during POST and shown here, allowing you to set the sequence that the BIOS uses to look for a device from which to load the OS. Below is a brief description of keyboard usage:

Key	Function
↑, ↓	Selects (highlight) a boot device.
1 to 4	Loads the default boot sequence.

**NOTE:** You can press the **f, r, x, -/+**, and **Shift + 1** keys by connecting a USB keyboard to your tablet PC. Make sure that the item "Legacy USB Support" under the Main menu is set at *Enabled* (default).

# Exit Menu

The Exit menu displays ways of exiting BIOS Setup Utility. After finishing with your settings, you must save and exit so that the changes can take effect.

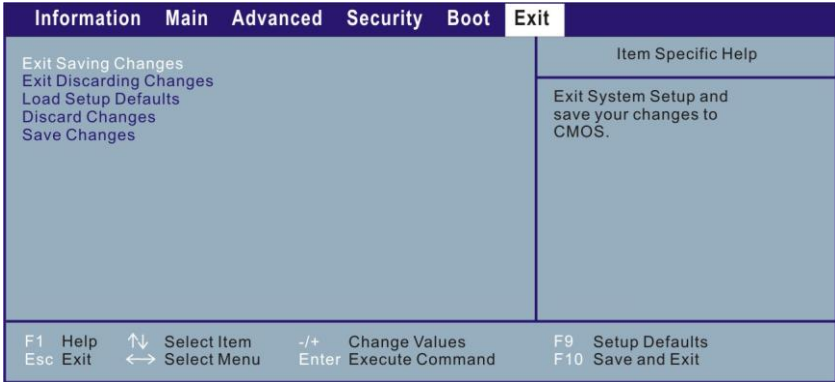

**Exit Saving Changes** saves the changes you have made and exits BIOS Setup Utility.

**Exit Discarding Changes** exits BIOS Setup Utility without saving the changes you have made.

**Load Setup Defaults** loads the factory default values for all the items.

**Discard Changes** restores the previous values for all the items.

**Saves Changes** saves the changes you have made.

# System Recovery

You need to run System Recovery when:

- Your Windows operating system does not start at all.
- You want to restore the factory default Windows settings.

**WARNING:** Using this feature will reinstall Windows to your system and configure it to the system's factory default settings. All data on the hard disk drive will be lost.

To run System Recovery:

1. During system startup when the following screen appears, press **Ctrl + Alt + F2** keys for four seconds or press **Ent** and select **HDI Recovery** when a small window appears on the screen.

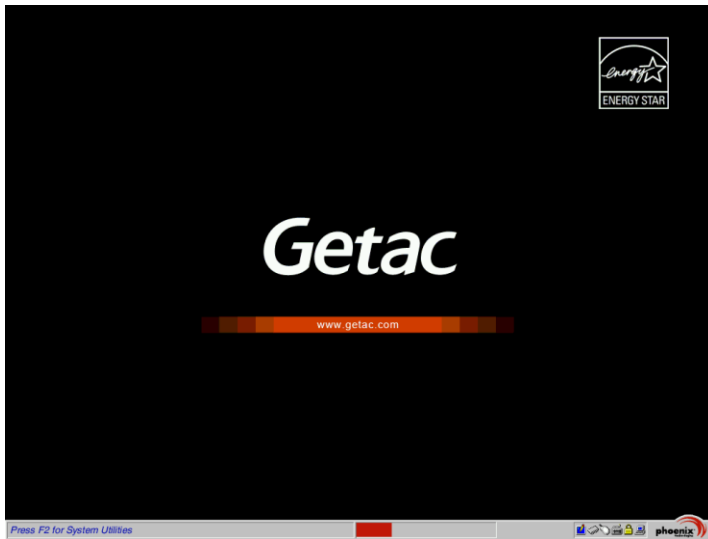

2. The message **This will help you reinstall Windows to the whole HDD to factory default. All data on HDD will be lost** appears on the screen to ask if you want to access System Recovery. Type **1** to continue or type **0** to exit.

3. A warning message appears as follows:  
\*\*\*\*\*  
You must accept the following terms before performing the recovery process:
  1. The recovery software is solely the purpose of reinstalling or restoring software associated with the hard disk of this operating GETAC machine.
  2. Except the above, no other use is granted hereunder.\*\*\*\*\*  
(1)Yes, I agree to the provisions of this agreement and wish to continue.  
(0)No, I do not agree to the provisions of this agreement and do not wish to continue.  
Type 1 to continue.
4. Type 1 again when the message Are you sure you want to recover now?  
(1)Yes (0)No appears onscreen.
5. Your system will start the recovery process and Windows operating system will be re-installed to its default setting.



# Chapter 6

## *Using Special Utilities*

Your tablet PC comes with an added security feature known as the TPM (Trusted Platform Module) – a component on your tablet PC's mainboard that is specifically designed to enhance platform security above-and- beyond the capabilities of today's software by providing a protected space for key operations and other security critical tasks.

The OSD Control Panel utility allows you to activate or operate certain functions on your tablet PC.

The G-Manager utility is a unified user interface utility that allows you to manage and configure various system components.

This chapter describes how to use these utilities.

# Using TPM (Trusted Platform Module)

TPM is a hardware-based security feature that can be used to create and manage computer-generated digital certificates. When combined with security software, the TPM enhances existing network and computer security by enabling features such as file protection capabilities and protected e-mail.

## NOTE:

- Make sure you select *Enable* on the **TPM Support** item under the **Security** menu of your BIOS Setup (see chapter 5 for details).
- Make sure you select *Enable & Activate* on the **Change TPM State** item under the **Security** menu of your BIOS Setup (see chapter 5 for details).
- You only need to activate these items once.

You can use the certificates to:

- Send and receive secure email from email clients like Microsoft Windows Mail/Outlook Express, Microsoft Outlook or Netscape Messenger
- Set up browser (e.g. Netscape Navigator or Internet Explorer) and web server (e.g. Microsoft Internet Information Server) for Client Authentication
- Sign Microsoft Word macros
- Encrypt files and folders
- Secure network connections

**NOTE:** For information on using the program and the different security features, click **Start** → **All Programs** → **Infineon Security Platform Solution** → **Help**.



# Using the OSD Control Panel

The OSD Control Panel allows you to activate or operate certain functions on your tablet PC.









To open the OSD Control Panel, press the **Menu** button on your tablet PC.











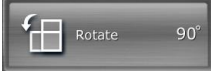



The following screen appears.



The following table shows the various functions on the OSD Control Panel.

Operation	OSD Control Panel Description
	<p>Switches the keypad lock ON and OFF. Press the button one second to turn ON (lock) and continuously for more than three seconds to turn OFF (unlock).</p> <p>This would prevent accidental pressing of the keypad buttons during transport.</p>
	<p>Switches the Fn keylock ON and OFF (  icon appears on the system tray when ON).</p> <p>You can use the secondary functions of keypad buttons with orange color on top of each button.</p>
	<p>A Help file explaining the OSD Control Panel.</p>
	<p>Turns on the Quick Button Setup utility (refer to the next section for details).</p>
	<p>Closes and exits the OSD Control Pane.</p>
	<p>Switches the RF module OFF and ON (wireless LAN, Bluetooth, 3G).</p> <p>Upon restarting your system, wireless LAN radio would be on even if you turned it off before system shutdown.</p>
	<p>Toggles the system power saving mode between <b>OFF / Work / Quick</b> and <b>Power Saving</b>.</p> <p>While entering into power saving mode, the system will turn down the panel backlight and sacrifices processing speed to gain more battery life. The <b>ECO</b> button works only when using battery power.</p>
	<p>The status would display <b>IN</b> when you connect your tablet PC to a docking station.</p> <p>To turn off power to the docking station without disconnecting from your tablet PC, click the <b>Docking</b> button.</p> <p>Before removing your tablet PC from the docking station, make sure to click the <b>Docking</b> button to show <b>OUT</b>.</p>

Operation	OSD Control Panel Description
	<p>Toggles between <b>NORMAL</b>, <b>MAX</b>, and <b>AUTO</b> brightness for LCD backlight.</p>
	<p>Rotates the LCD display orientation from default landscape to <b>90°</b> portrait, <b>180°</b> landscape, <b>270°</b> portrait, and vice versa.</p>
	<p>Toggles between <b>LCD</b>, <b>VGA</b> (external device e.g., monitor), and <b>BOTH</b> (LCD and external device). Switches the display output when external devices are connected. If the external device is not connected, the choice would only be <b>LCD</b>. Upon restarting your system, the setting would be <b>LCD</b> only.</p>
	<p>Serves as the default Microsoft® Internet Explorer quick launch button. You can use the Quick Button Setup utility to assign a different function to this button (refer to the next section for details).</p>
	<p>Serves as the default Microsoft® Outlook Express quick launch button. You can use the Quick Button Setup utility to assign a different function to this button (refer to the next section for details).</p>
	<p>Serves as the default LCD display calibration tool quick launch button. You can use the Quick Button Setup utility to assign a different function to this button (refer to the next section for details).</p>
	<p>Serves as the default Bluetooth® wireless setup quick launch button. You can use the Quick Button Setup utility to assign a different function to this button (refer to the next section for details).</p>

Operation	OSD Control Panel Description
	<p>Serves as the default virtual keyboard quick launch button.</p> <p>You can use the Quick Button Setup utility to assign a different function to this button (refer to the next section for details).</p>
	<p>Increases or decreases the sound volume. This function adjusts the volume of sound output both from the speakers and headphones. It is synchronized with your Windows main volume controller.</p> <p>Upon restarting your system, Windows will memorize the last setting before system shutdown.</p>
	<p>Increases or decreases the LCD brightness level.</p> <p>Upon restarting your system, Windows will memorize the last setting before system shutdown.</p>
	<p>Switches the system sound output OFF (mute) and ON. This function mutes the sound output both from the speakers and headphones. It is synchronized with your Windows main volume controller.</p> <p>Upon restarting your system, Windows will memorize the last setting before system shutdown.</p>
	<p>System enters "black-out" mode by turning off the LCD display, LED indicators, touchscreen, and sound volume.</p> <p>Press the power button (  ) to wake up the system from "black-out" mode.</p>

# Quick Button Setup Utility

By default, the five quick launch buttons on the OSD Control Panel have pre-assigned functions.



The Quick Button Setup utility allows you to re-define the above five quick launch buttons. To re-define:

1. Click the Quick Button Setup utility button (  ) and the **Quick Button Setup** window appears as shown next.

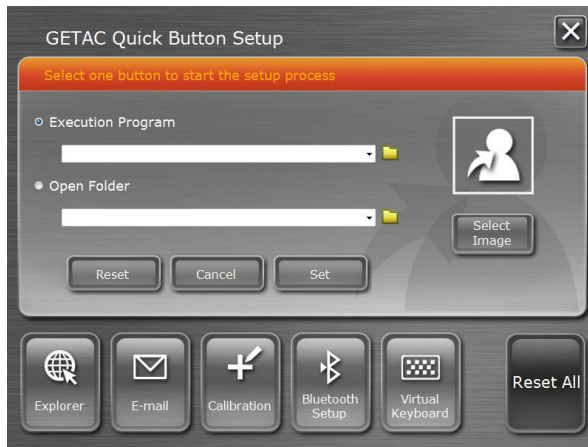

2. To re-assign a program to a button, click to select a particular button to change (e.g., Explorer), then click the folder icon.



3. The **Select a File to Open** dialog box appears as shown next. Select the desired program, then click **Open** to complete the process.

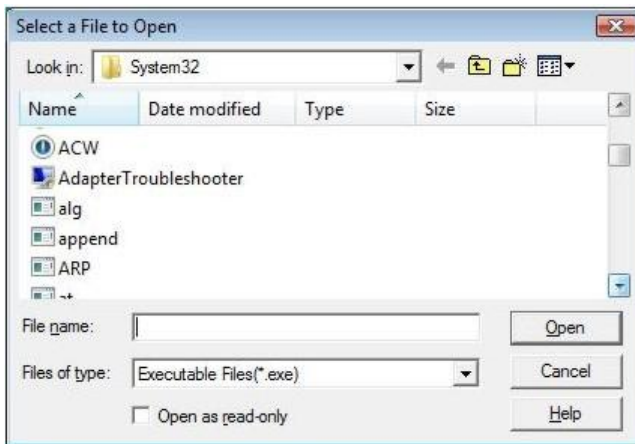

4. You can change the image appearing on the button by clicking the **Select Image** icon.

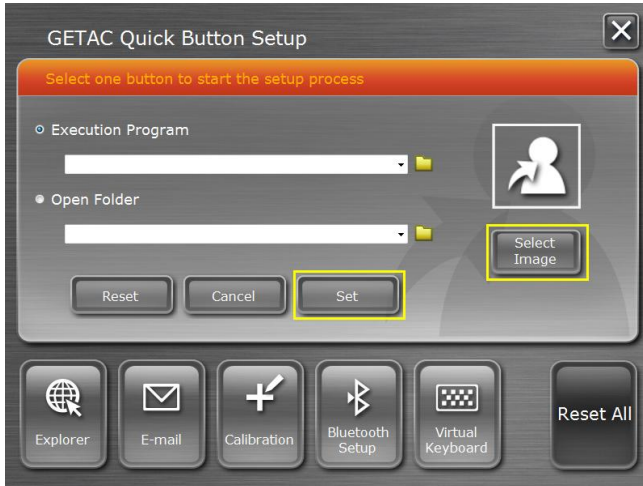

5. The **Select Picture** dialog box appears as shown next. After selecting the image file, the appropriate icon will then appear in the button.

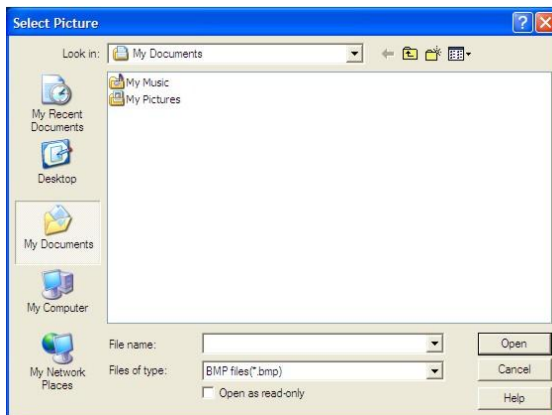

6. Click **Set** to complete the changes.

# Using the G-Manager Utility

G-Manager is a unified user interface utility that allows you to manage and configure the following:

- System
- Battery
- Light Sensor
- ECO (economy mode)
- Ignition
- Monitoring
- Antenna
- GPS Status

## Starting G-Manager

You can start up G-Manager by any of the following methods:

- Click **Start** → **All Programs** → **GETAC Utility** → **G-Manager**, or
- Right-click on the GETAC Utility icon (  ) located on the system tray and click **G-Manager**.



# System Tab

The **System** tab provides an overview of the system status.

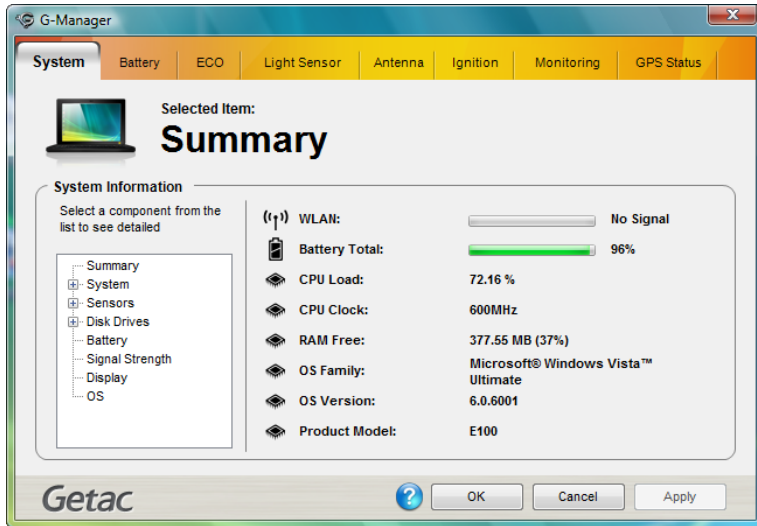

The component to be viewed is selected from the tree view list on the left side of the screen. It contains eight major components namely:

- Summary
- System
- Sensors
- Disk Drives
- Battery
- Signal Strength
- Display
- OS (operating system)

The status of the selected component is displayed on the right side of the screen.

## Battery Tab

The **Battery** tab allows you to minimize deterioration of the battery thereby ensuring a longer battery life. At most two batteries may be supported.

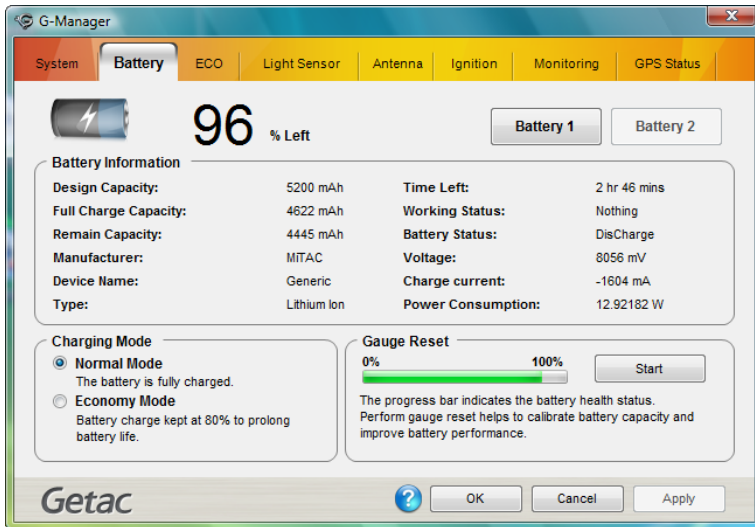

Press **Battery 1** or **Battery 2** to view the details and configuration settings of each battery.

## Battery Information

The upper portion of the Battery tab contains a live update of information about the selected battery.

### NOTE:

- When the percentage **% Left** is less than 10% then the value will be displayed in **red**.

- When an abnormal battery condition is detected **Battery Status** value will be displayed in **red**.

## Charging Mode

The lower left portion of the Battery tab allows you to select the charging mode.

- **Normal Mode** – the battery will be fully charged. When remaining charge reaches below 95%, then charging will start until it is fully charged.
- **Economy Mode** – to help prolong battery life the battery will be charged up to 80% of its total capacity only. Highly recommended when you are using AC power most of the time.

## Gauge Reset

The lower right portion of the Battery tab allows you to discharge and recharge the battery in order to activate certain physical attributes periodically. The percentage bar shows the battery health.

The low health bar percentage indicates the poorer health of the battery, therefore the need to perform the gauge reset in order to calibrate battery's capacity and improve the battery's performance.

To perform a gauge reset:

1. Click **Perform Gauge Reset** to perform a gauge reset and the following screen appears.

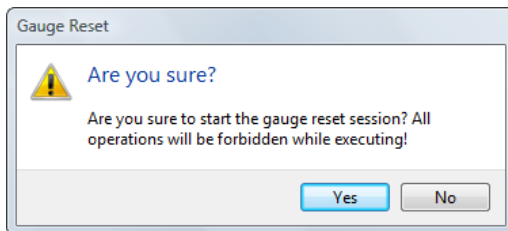

- Click **Yes** to start the gauge reset session and the following screen appears.

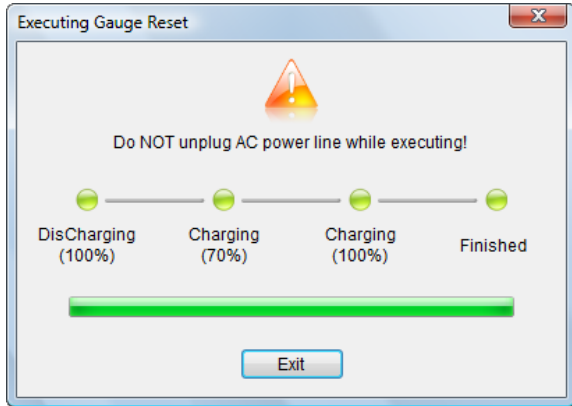

The percentage of completion will be shown on the progress bar. Depending on the number of battery, the screen will show the corresponding number of batteries to perform gauge reset. The value of **Working Status** will show in **red** alternately.

You can click **Cancel** anytime to stop gauge reset.

**NOTE:** When a gauge reset is in progress, do not execute other operation except to click **Cancel** to stop gauge reset.

# Light Sensor Tab

The **Light Sensor** tab allows you to adjust the LCD brightness based on your surrounding's lighting condition.

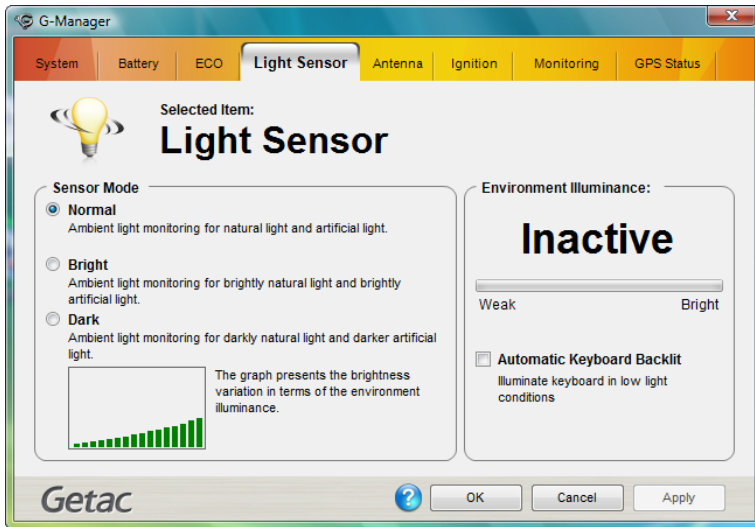

## Sensor Mode

The left portion of the Light Sensor tab allows you to select the sensor mode.

- **Normal** – light sensor sensitivity is set at normal environment lighting condition.
- **Bright** – light sensor sensitivity is set at bright environment lighting condition (e.g. outdoors).
- **Dark** – light sensor sensitivity is set at dark environment lighting condition (e.g. indoors, storage warehouse, etc.).

The lower left portion of the Light Sensor tab shows the selected sensor mode's graph.

The upper right portion of the Light Sensor tab shows the active profile based on your selection on sensor mode.

The middle right portion of the Light Sensor tab shows the environment luminance (degree of Lux from weak to bright) as detected by your tablet PC's light sensor.

The lower right portion of the Light Sensor tab allows your system to illuminate the keypad in poor lighting environment by selecting the checkbox **Automatic Keyboard Backlit**.

## ECO Tab

The **ECO** tab allows you to manage the system's power consumption.

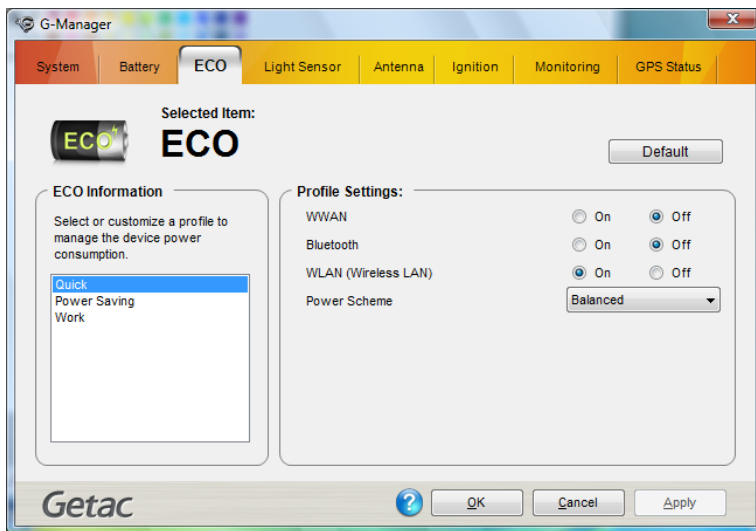

**NOTE:** The items appearing on the ECO tab may differ depending on your model.

## ECO Information

Depending on the system, the left portion of the ECO tab shows the available profile to manage the system's power consumption.

## Active Profile

The right upper portion of the ECO tab shows the name of the current profile selected.

## Profile Settings

The lower right portion of the ECO tab contains the following:

- Turn on/off the following for power saving: WWAN, Bluetooth, WLAN, and optical disk drive.
- **Power Scheme** – select **Home/Office Desk, Portable/Laptop, Presentation, Always On, Minimal Power Management, or Max Battery** if your system is running Windows XP. Select **Balanced, High Performance or Power Saver** if the system is running Windows Vista. The setting here will correspond to your settings in Windows. (See Windows Help for the description to each of the power scheme.)
- **Brightness** – adjust the brightness setting from 0 ~ 63. This option is not available on systems running Windows Vista.
- **Default** – revert back to original profile setting.

# Ignition Tab

The **Ignition** tab allows you to set if the system is deriving power from your vehicle.

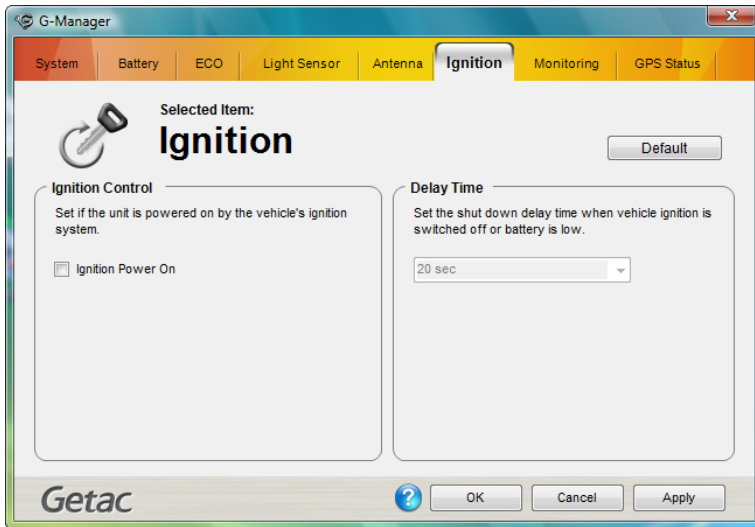

## Ignition Control

The left portion of the Ignition tab allows your system to derive power from the vehicle as well as boot up your tablet PC by selecting the checkbox **Ignition Power On**. Your tablet PC will also shutdown when you turn off ignition to your vehicle. The amount of time between turning off your vehicle and tablet PC shutdown would depend on your setting on the next section Delay Time. This feature is only available when your tablet PC is docked to the GETAC docking station.





## Delay Time

The right portion of the Ignition tab allows you to set the delay time (20 seconds, 30 seconds, 45 seconds, 1 minute, or 2 minute) to shut down the system when you turn off vehicle ignition. This will help prevent the tablet PC from using up the vehicle's battery power thereby causing poor vehicle startup.

## Monitoring Tab

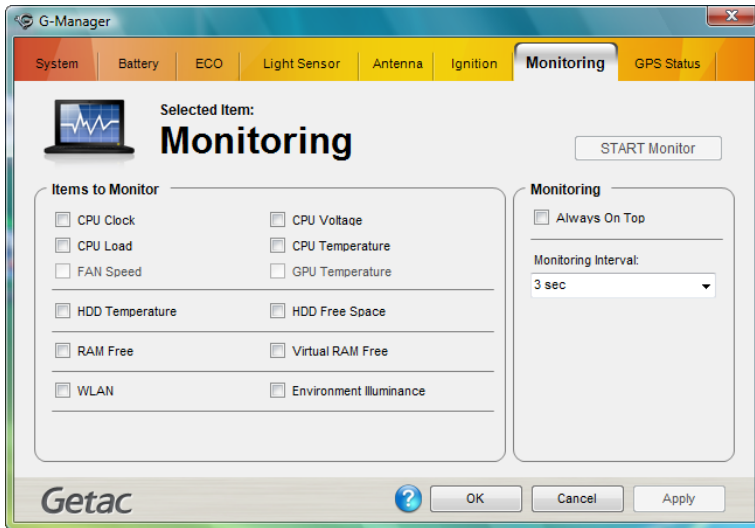
The **Monitoring** tab allows you to select the items on your system to monitor.



Press **OK** and right-click on the G-manager icon (  ) located on the system tray and click **Start Monitor**. The changes made to the monitoring options are immediately implemented on the monitoring window.

To exit the monitor function, right-click on the G-manager icon (  ) located on the system tray and click **Stop Monitor**.

## Items to Monitor

The left portion of the Monitoring tab allows you to select which item to monitor by selecting on the checkbox before each item. When enabled the status of the selected Item is displayed and a live update is shown on the screen. Items with higher priority are shown on top of items with lower priority (see the next table).

Priority	Monitoring Items
1	CPU clock
2	CPU load
3	CPU voltage
4	CPU temperature
5	RAM free
6	Virtual RAM free
7	Battery left time
8	Battery left percentage

Priority	Monitoring Items
9	WLAN
10	GPU temperature
11	GMCH 1 temperature
12	GMCH 2 temperature
13	HDD temperature
14	HDD free space
15	Fan speed
16	Environment luminance

Different model have different supported monitoring items; non-supported items cannot be selected (gray out item).

## Monitoring Options

The right portion of the Monitoring tab allows you to set how the monitored items are displayed. The changes made to the monitoring options are immediately implemented on the monitoring window.

- **Always On Top** – allows the monitoring window to remain on top of your display.
- **Background Color** – select this option to display the color window for selecting the background color. If the checkbox is not selected, the background of the monitoring window is transparent.
- **Monitoring Interval** – allows you to set the frequency of updates on the monitoring window (1/3/5/10/30 seconds, or 1/5/30 minutes, or 1 hour).

- **Transparency** – allows you to set the level of transparency of the monitoring window (10 ~ 90 %).

## Antenna Tab

The **Antenna** tab allows your system to connect to an external GPS or 3G antenna.

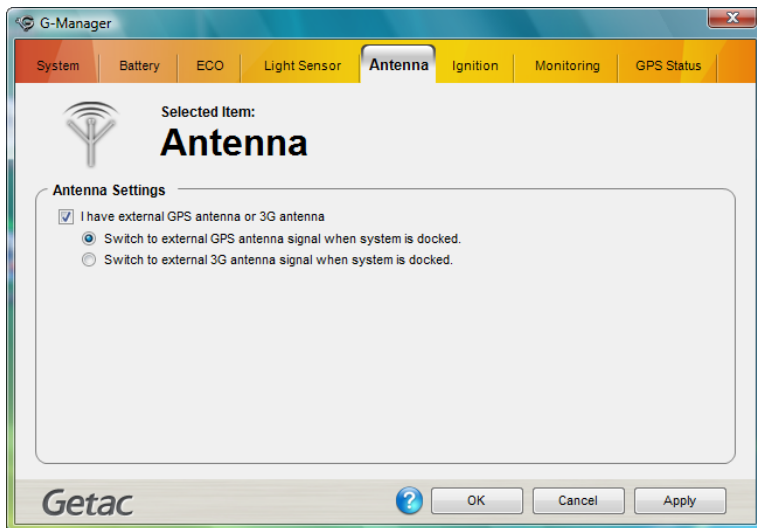

Select the checkbox **I have external GPS antenna or 3G antenna** to allow your system to connect to an external GPS/3G antenna. When this option is selected, you can choose the following:

- Switch to external GPS antenna signal when system is docked.
- Switch to external 3G antenna signal when system is docked.

# GPS Status Tab

The **GPS Status** tab shows the GPS signal availability status of the system's GPS module, allowing you to check if the GPS feature is working properly. You may also need to install a third-party map of your particular location (purchased separately).

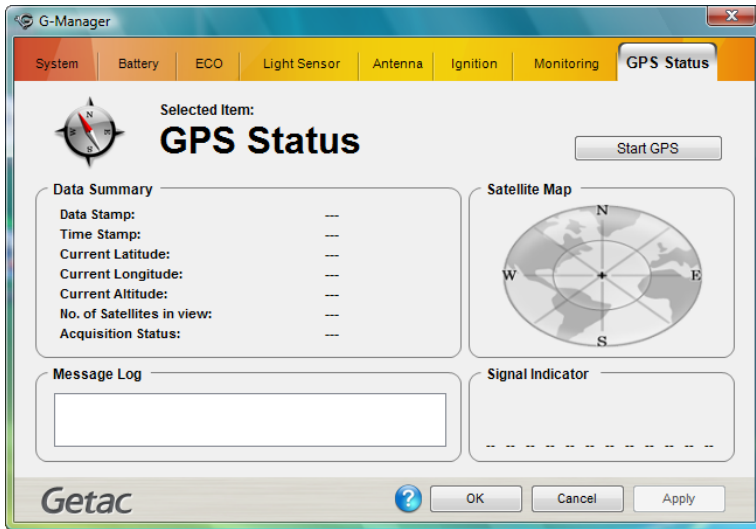

## Selected Item and Data Summary

The upper left portion of the GPS Status tab shows the various data (Date Stamp, Time Stamp, Current Latitude, Current Longitude, Current Altitude, No. of Satellites in View, and Acquisition Status) collected from satellites and reflect any changes to the data.

Unlike the other items, **Acquisition Status** only shows whether GPS signal acquisition is successful or not.

## Message Log

The lower left portion of the GPS Status tab shows a summary of raw data string received from satellites which can only be viewed but not editable. The Message Log window is auto-scrollable and will be cleared as soon as GPS signal is disconnected.

## Satellite Map

The upper right portion of the GPS Status tab shows the satellites discovered and are placed on the satellite map according to their parsed latitude and longitude. Satellites in use are displayed in **yellow** color with their PRN number while satellites in view but not in use are displayed in **blue** color.

## Signal Indicator

The lower right portion of the GPS Status tab shows the 12 satellites' signal indicator. The length of the green bar underneath each satellite changes dynamically, the stronger the signal the longer the bar shown. Beneath each signal bar is the PRN number of each discovered satellite ("00" is shown when GPS module is not functioning or satellite was not discovered).

## Open/Close GPS

This button allows you to test the GPS module. Upon clicking on **Open GPS**, the following three conditions may be shown:

- GPS module has successfully connected –  
The button changes from "Opening . . ." to "Close GPS." The item **Acquisition Status** under the Data Summary portion of the GPS Status tab will change from "Inactive" to "Acquiring . . ." and begin the positioning process. It will then change to "Acquired" when GPS module has successfully been positioned.
- GPS COM port is not available –  
When other GPS program is running, a warning window pops-up and displays the message "GPS COM port not available! Please close all GPS program and try again." to inform you to close the other GPS program

to free up the COM port. After closing the other GPS program, click Open GPS button again to try.

- GPS COM port is somehow not functioning –  
A warning window pops-up and displays the message “Time out opening GPS COM port!” when GPS COM port is not responding after 5 seconds.

Upon clicking on **Close GPS**, the GPS COM port will be closed and the button will change to show **Open GPS**. All information under the Satellite Map, Signal Indicator, Message Log, and Data Summary portion of the GPS Status tab is cleared except for the item Acquisition Status which will show “Inactive.”

GPS connection will be automatically closed whenever G-Manager is closed.

## Chapter 7

# *Caring for the Tablet PC*

Taking good care of your tablet PC will ensure a trouble-free operation and reduce the risk of damage to your tablet PC.

This chapter gives you guidelines covering areas such as protecting, storing, cleaning, and traveling.

# Protecting the Tablet PC

To safeguard the integrity of your tablet PC data as well as the tablet PC itself, you can protect the tablet PC in several ways as described in this section.

## Using the Cable Lock

You can use a Kensington-type cable lock to protect your tablet PC against theft. The cable lock is available in most tablet PC stores.

To use the lock, loop the lock cable around a stationary object such as a table. Insert the lock to the Kensington lock hole and turn the key to secure the lock. Store the key in a safe place.





# Taking Care of the Tablet PC

## Location Guidelines

- For optimal performance, use the tablet PC where the recommended temperature is between 10 °C (50 °F) and 35 °C (95 °F) – actual operating temperature depending on product specifications.
- Avoid placing the tablet PC in a location subject to high humidity, extreme temperatures, mechanical vibration, direct sunlight, or heavy dust.
- Do not cover or block any ventilation openings on the tablet PC. For example, do not place the tablet PC on a bed, sofa, rug, or other similar surface. Otherwise, overheating may occur that results in damage to the tablet PC.
- Keep the tablet PC at least 13 cm (5 inches) away from electrical appliances that can generate a strong magnetic field such as a TV, refrigerator, motor, or a large audio speaker.
- Avoid moving the tablet PC abruptly from a cold to a warm place. A temperature difference of more than 10 °C (18 °F) may cause condensation inside the unit, which may damage the storage media.
- Do not place the tablet PC on an unsteady surface.

## General Guidelines

- Do not place heavy objects on top of the tablet PC as this may damage the display.
- The screen surface is easily scratched. Do not use paper towels to clean the display but use the included soft cloth. Avoid touching it with your fingers, pen, or pencil.
- To maximize the life of the backlight in the display, allow the backlight to automatically turn off as a result of power management. Avoid using

a screen saver or other software that prevents the power management from working.

## Cleaning Guidelines

- Never clean the tablet PC with its power on.
- Use a soft cloth moistened with water or a non-alkaline detergent to wipe the exterior of the tablet PC.
- Gently wipe the display with a soft, lint-free cloth. Do not use alcohol or detergent on the display.

## Battery Pack Guidelines

- Recharge the battery pack when it is nearly discharged. When recharging, make sure that the battery pack is fully charged. Doing so may avoid harm to the battery pack.
- The battery pack is a consumable product and the following conditions will shorten its life:
  - when frequently charging the battery pack (it is recommended that you set the **Charging Mode** on the G-Manager utility's **Battery** tab to **Economy Mode** – see chapter 6 for details).
  - when using, charging, or storing the battery in high temperature condition
- To avoid hastening the deterioration of the battery pack thereby prolonging its useful life, minimize the number of times you charge it so as not to frequently increase its internal temperature.
- Charge the battery pack between 5°C ~ 45°C (41°F ~ 113°F) temperature range.  
A higher environment temperature will cause the battery pack's temperature to rise. Avoid charging the battery pack inside a closed vehicle and in hot weather condition.  
Also, charging will not start if the battery pack is not within the allowed temperature range.

- It is recommended that you do not charge the battery pack more than once a day.
- It is recommended that you charge the battery pack with the tablet PC's power off.
- To maintain the battery pack's operating efficiency, store it in a cool dark place removed from the tablet PC and with 30 % ~ 40 % charge remaining.
- Important guidelines when using the battery pack.

When installing or removing the battery pack take note of the following:

- avoid installing or removing the battery pack when the tablet PC is in Standby mode. Abruptly removing the battery pack may cause loss of data or the tablet PC may become unstable.
- avoid touching the battery pack terminals or damage may occur, thereby causing improper operation to it or the tablet PC.

The tablet PC's input voltage and surrounding temperature will directly affect the battery pack's charge and discharge time:

- charging time will be prolonged when the tablet PC is turned on. To shorten the charging time, it is recommended that you place the tablet PC in standby or hibernation mode.
- a low temperature will prolong the charging time as well as hasten the discharge time.

## Touchscreen Guidelines

- Use the finger or the included touchscreen pen on the display. Using a sharp or metallic object other than your finger or touchscreen pen may cause scratches and damage the display, thereby causing errors.
- A screen protector film has been attached to the screen before shipment. The film is a consumable, which will be worn out after a period of use (6 months in average). You can purchase a new one when replacement is required.
- Avoid using excessive force that may cause damage to the display.

- Use a soft cloth to remove dirt on the display. The touchscreen surface has a special protective coating that prevents dirt from sticking to it. Not using a soft cloth may cause damage to the special protective coating on the touchscreen surface.  
To remove hard to remove dirt, blow some steam on the particular area and gently wipe away using a soft cloth.
- Turn off the tablet PC power when cleaning the display. Cleaning the display with the power on may cause improper operation.
- Use the touchscreen within the intended area only. The display area and touchscreen operating area is the same.
- Do not use excessive force on the display. Avoid placing objects on top of the display as this may cause the glass to break thereby damaging the display.
- Using the touchscreen during low temperature (less than 5 °C) may cause a slower response time, this is normal. A normal response time may be restored upon returning to room temperature.
- When there is noticeable discrepancy in the operation of the touchscreen function (wrong location on intended operation or improper display resolution), refer to the Windows operating system for instructions on recalibrating the touchscreen display.

# When Traveling

- Before traveling with your tablet PC, make a backup of your hard disk data into flash disks or other storage devices. As an added precaution, bring along an extra copy of your important data.
- Make sure that the battery pack is fully charged.
- Make sure that the tablet PC is turned off.
- Disconnect the AC adapter from the tablet PC and take it with you. Use the AC adapter as the power source and as a battery-charger.
- Hand-carry the tablet PC. Do not check it in as luggage.
- If you need to leave the tablet PC in the car, put it in the trunk of the car to avoid exposing the tablet PC to excessive heat.
- When going through airport security, it is recommended that you send the tablet PC and flash disks through the X-ray machine (the device you set your bags on). Avoid the magnetic detector (the device you walk through) or the magnetic wand (the handheld device used by security personnel).
- If you plan to travel abroad with your tablet PC, consult your dealer for the appropriate AC power cord for use in your country of destination.



# Chapter 8

## *Troubleshooting*

Tablet PC problems can be caused by hardware, software, or both. When you encounter any problem, it might be a typical problem that can easily be solved.

This chapter tells you what actions to take when solving common tablet PC problems.

# Preliminary Checklist

Here are helpful hints to follow before you take further actions when you encounter any problem:

- Try to isolate which part of the tablet PC is causing the problem.
- Make sure that you turn on all peripheral devices before turning on the tablet PC.
- If an external device has a problem, make sure that the cable connections are correct and secure.
- Make sure that the configuration information is properly set in the BIOS Setup program.
- Make sure that all the device drivers are correctly installed.
- Make notes of your observations. Are there any messages on the screen? Do any indicators light? Do you hear any beeps? Detailed descriptions are useful to the service personnel when you need to consult one for assistance.

If any problem persists after you follow the instructions in this chapter, contact an authorized dealer for help.



# Solving Common Problems

## Battery Problems

**The battery does not charge (Battery Charge indicator does not light amber).**

- Make sure that the AC adapter is properly connected.
- Make sure that the battery is not too hot or cold. Allow time for the battery pack to return to room temperature.
- Make sure that the battery pack is installed correctly.
- Make sure that the battery terminals are clean.

**The operating time of a fully charged battery becomes shorter.**

- If you often partially recharge and discharge, the battery might not be charged to its full potential. Initialize the battery to solve the problem. (See “Initializing the Battery Pack” in Chapter 3 for instructions.)

**The battery operating time indicated by the battery meter does not match the actual operating time.**

- The actual operating time can be different from the estimated time, depending on how you are using the tablet PC. If the actual operating time is much less than the estimated time, initialize the battery. (See “Initializing the Battery Pack” in Chapter 3 for instructions.)

## *Bluetooth* Wireless Transmission Problems

**I cannot connect to another device with *Bluetooth* wireless technology.**

- Make sure that both devices have activated *Bluetooth* feature.
- Make sure that the distance between the two devices are not over 10 meters or that there are no walls or other obstructions between the devices.

- Make sure that the other device is not in “Hidden” mode.
- Make sure that both devices are compatible.

## Display Problems

### **Nothing appears on the screen.**

- During operation, the screen may automatically turn off as a result of power management. Press any key to see if the screen comes back.
- The brightness level might be too low. Increase brightness by pressing the  button.

### **The characters on the screen are dim.**

- Adjust the brightness and/or contrast.

### **Bad dots appear on the display at all times.**

- A small number of missing, discolored, or bright dots on the screen are an intrinsic characteristic of TFT LCD technology. It is not regarded as a LCD defect.

## Hardware Device Problems

### **The tablet PC does not recognize a newly installed device.**

- The device may not be correctly configured in the BIOS Setup program. Run the BIOS Setup program to identify the new type.
- Make sure if any device driver needs to be installed. (Refer to the documentation that came with the device.)
- Make sure if the device needs any jumper or switch settings. (Refer to the documentation that came with the device.)
- Check the cables or power cords for correct connections.
- For an external device that has its own power switch, make sure that the power is turned on.

# Hard Disk Drive Problems

**The hard disk drive error message appears on the screen.**

- The hard disk drive has defects. Ask your dealer for help.

**The hard disk drive operations seem slow.**

- The data files stored on the hard disk drive may be fragmented. Use a tool such as Window's **Disk Defragmenter** to defragment the files.

**The hard disk drive / heater indicator (  ) glows without blinking.**

- The data files stored on the hard disk drive may be fragmented. Use a tool such as Window's **Disk Defragmenter** to defragment the files.

**The hard disk drive / heater indicator glows red.**

- When the tablet PC is connected to AC power and hard disk drive temperature is below 5 °C, the optional heater would turn on (if the item **HDD Preheat** under the Advanced menu of your BIOS Setup is set at *Enabled*). Wait awhile.

# LAN Problems

**I cannot access the network.**

- Make sure that the LAN cable is properly connected to the RJ-45 connector (  ) and the network hub.
- Make sure that the network configuration is appropriate.
- Make sure that the user name or password is correct.

# Wireless LAN Problems

**I cannot use the wireless LAN feature.**

- Make sure that the wireless LAN feature is turned on.

### **Transmission quality is poor.**

- Your tablet PC may be in an out-of-range situation. Move your tablet PC closer to the Access Point or another wireless LAN device it is associated with.
- Check if there is high interference around the environment and solve the problem as described next.

### **Radio interference exists.**

- Move your tablet PC away from the device causing the radio interference such as microwave oven and large metal objects.
- Plug your tablet PC into an outlet on a different branch circuit from that used by the affecting device.
- Consult your dealer or an experienced radio technician for help.

### **I cannot connect to another wireless LAN device.**

- Make sure that the wireless LAN feature is turned on.
- Make sure that the SSID setting is the same for every wireless LAN device in the network.
- Your tablet PC is not recognizing changes. Restart the tablet PC.
- Make sure that the IP address or subnet mask setting is correct.

### **I cannot communicate with the computer in the network when Infrastructure mode is configured.**

- Make sure that the Access Point your tablet PC is associated with is powered on and all the LEDs are working properly.
- If the operating radio channel is in poor quality, change the Access Point and all the wireless station(s) within the BSSID to another radio channel.
- Your tablet PC may be in an out-of-range situation. Move your tablet PC closer to the Access Point it is associated with.
- Make sure that your tablet PC is configured with the same security option (encryption) to the Access Point.

- Use the Web Manager/Telnet of the Access Point to check whether it is connected to the network.
- Reconfigure and reset the Access Point.

### **I cannot access the network.**

- Make sure that the network configuration is appropriate.
- Make sure that the user name or password is correct.
- You have moved out of range of the network.
- Turn off power management.

## **PC Card Problems (Optional)**

### **The PC card does not work.**

- Make sure that the PC card is correctly seated.
- If the card requires an IRQ (Interrupt ReQuest), make sure that there is one available.

### **The PC card stops communicating properly.**

- The application may have been reset when the tablet PC is turned off or in Standby/Sleep mode. Exit and restart the application.

## **Power Management Problems**

### **The tablet PC does not enter Standby or Hibernation mode automatically.**

- If you have a connection to another computer, the tablet PC does not enter Standby or Hibernation mode if the connection is actively in use.
- Make sure that the Standby or Hibernation time-out is enabled.

### **The tablet PC does not enter Standby or Hibernation mode immediately.**

- If the tablet PC is performing an operation, it normally waits for the operation to finish.

### **The tablet PC does not resume from Standby or Hibernation mode.**

- The tablet PC automatically enters Standby or Hibernation mode when the battery pack is empty. Do any one of the following:
  - Connect the AC adapter to the tablet PC.
  - Replace the empty battery pack with a fully charged one.

## **Software Problems**

### **An application program does not work correctly.**

- Make sure that the software is correctly installed.
- If an error message appears on the screen, consult the software program's documentation for further information.
- If you are sure the operation has stop, reset the tablet PC. (See "Resetting the Tablet PC" later in this chapter.)

## **Sound Problems**

### **No sound is produced.**

- Make sure that the volume control is not set too low. Increase volume by pressing the  button.
- Make sure that the tablet PC is not in Standby mode.
- If using an external speaker, make sure that the speaker is properly connected.

### **Distorted sound is produced.**

- Make sure that the volume control is not set too high or too low. In most cases, a high setting can cause the audio electronics to distort the sound.

### **The external audio device does not work.**

- Make sure that your tablet PC is equipped with the driver needed.
- Click the speaker symbol on the taskbar and check the Windows volume control.

- Check the volume control of your tablet PC.

## Startup Problems

### When you turn on the tablet PC, it does not respond and the Power Indicator does not light green.

- If you are using an external AC power, make sure that the AC adapter is correctly and securely connected. If so, make sure that the electrical outlet works properly.
- If you are using the battery power, make sure that the battery is not discharged.
- When the tablet PC is connected to AC power and hard disk drive temperature is below 5 °C, the optional heater would turn on as indicated by the hard disk drive / heater indicator (  ) glowing in red (if the item **HDD Preheat** under the Advanced menu of your BIOS Setup is set at *Enabled*). Wait awhile.

### When you turn on the tablet PC, it stops after POST.

- Restart your tablet PC.

## Other Problems

### The date/time is incorrect.

- Correct the date and time via the operating system or BIOS Setup program.
- After you have performed everything as described above and still have the incorrect date and time every time you turn on the tablet PC, the RTC (Real-Time Clock) battery is at the end of its life. Call an authorized dealer to replace the RTC battery.

# Resetting the Tablet PC

You may have to reset (reboot) your tablet PC on some occasions when an error occurs and the program you are using hangs up.

If the tablet PC operation seems to hang up, first wait. It is possible that the tablet PC is processing data. Periodically check the hard disk drive in-use indicator, if it flashes irregularly, the program may be accessing data and preventing you from using the keypad. If you are sure the operation has stopped and you cannot use the “restart” function of the operating system, reset the tablet PC.

Reset the tablet PC by any one of these methods:

- Press the **Fn** button, then press **C+A+D** button on your built-in keypad.
- If the above action does not work, turn off the tablet PC. Wait for at least five seconds and turn it on again.

**CAUTION:** Resetting will cause any unsaved data to be lost.



# Appendix A

## Specifications

**NOTE:** Specifications are subject to change without any prior notice.

Parts		Specifications
CPU		Intel® A110 processor, 512 KB L2 cache, 800 MHz
RAM (system)		Up to 1 GB DDRII DRAM
Display	Panel	8.4-inch wide TFT LCD, SVGA transmissive display, integrated touchscreen, 800 Nits LCD brightness (option)
Audio	Features	High Definition audio, volume control via keypad and software
	Speaker	Integrated speaker
	Port	Line-out
Hard disk drive		Shock-mounted, 60/80/120 GB
Card slots		Smart Card
I/O ports		USB (2.0) ports × 2, RJ-45 port, audio line-out port, PCMCIA connector (option), Smart Card connector, docking connector
LAN		10/100/1000 Mbps Ethernet
Wireless LAN		IEEE 802.11b/g, AES, TKIP, WEP, 802.11i/WPA2 security, authentication 802.1x, 802.11e/WMM Quality of Service
<i>Bluetooth</i>		<i>Bluetooth</i>
GPS (option)		Integrated Global Positioning System (GPS) receiver module (with antenna pass-through)
WWAN (option)		CDMA / EV-DO / 1xRTT or HSDPA/UMTS/GPRS/GSM (with antenna pass-through)
Security		Kensington lock TPM 1.2 (availability may vary) Smart Card Reader
Power	Battery	Li-ion smart battery 5100 mA/7.4 V or above
Dimension (LxWxD)		280×184×32 mm (11×7.2×1.3 inch)
Weight		1.4 kg (3.09 lb)

Parts		Specifications
Environment	Temperature	Operating: -20 °C (-4 °F) to 60 °C (140 °F) Storage: -40 °C (-40 °F) to 75 °C (167 °F) Thermal shock: -20 °C (-4 °F) to 60 °C (140 °F)
	Humidity	Relative: 0 % to 95 % non-condensing
Compliance		MIL-STD 810F and IP54

# Appendix B

## *Regulatory Information*

This appendix provides regulatory statements and safety notices on your tablet PC.

**NOTE:** Marking labels located on the exterior of your tablet PC indicate the regulations that your model complies with. Please check the marking labels and refer to the corresponding statements in this appendix. Some notices apply to specific models only.

# On the Use of the System

## Class B Regulations

### USA

#### Federal Communications Commission Radio Frequency Interference Statement

##### NOTE:

This equipment has been tested and found to comply with the limits for a Class B digital device pursuant to Part 15 of the FCC Rules. These limits are designed to provide reasonable protection against harmful interference in a residential installation. This equipment generates, uses, and can radiate radio frequency energy and, if not installed and used in accordance with the instructions, may cause harmful interference to radio communications. However, there is no guarantee that interference will not occur in a particular installation. If this equipment does cause harmful interference to radio or television reception, which can be determined by turning the equipment off and on, the user is encouraged to try to correct the interference by one or more of the following measures:

- Reorient or relocate the receiving antenna.
- Increase the separation between the equipment and receiver.
- Connect the equipment into an outlet on a circuit different from that to which the receiver is connected.
- Consult the dealer or an experienced radio/TV technician for help.

Any changes or modifications not expressly approved by the manufacturer could void the user's authority to operate the equipment.

##### Please note:

The use of a non-shielded interface cable with this equipment is prohibited.

# Canada

## Canadian Department of Communications Radio Interference Regulations Class B Compliance Notice

This Class B digital apparatus meets all requirements of the Canada Interference-Causing equipment regulations.

Cet appareil numérique de Classe B respecte toutes les exigences du Règlement Canadien sur le matériel brouilleur.

This digital apparatus does not exceed the Class B limits for radio noise emissions from digital apparatus set out in the Radio Interference Regulations of the Canadian Department of Communications.

Le présent appareil numérique n'émet pas de bruits radioélectriques dépassant les limites applicables aux appareils numériques de la classe B prescrites dans le Règlement sur le brouillage radioélectrique édicté par le ministère des Communications du Canada.

## Safety Notices

### About the Battery

#### Caution Texts Concerning Lithium Batteries

##### **DANISH**

ADVARSEL! Lithiumbatteri – Eksplosionsfare ved fejlagtig håndtering. Udskiftning må kun ske med batteri af samme fabrikat og type. Levér det brugte batteri tilbage til leverandøren.

##### **NORWEGIAN**

ADVARSEL: Eksplosjonsfare ved feilaktig skifte av batteri. Benytt samme batteritype eller en tilsvarende type anbefalt av apparatfabrikanten. Brukte batterier kasseres i henhold til fabrikantens instruksjoner.

##### **SWEDISH**

VARNING: Explosionsfara vid felaktigt batteribyte. Använd samma batterityp eller en ekvivalent typ som rekommenderas av apparattillverkaren. Kassera använt batteri enligt fabrikantens instruktion.

## **FINNISH**

**VAROITUS:** Paristo voi räjähtää, jos se on virheellisesti asennettu. Vaihda paristo ainoastaan valmistajan suosittelemaan tyyppiin. Hävitä käytetty paristo valmistajan ohjeiden mukaisesti.

## **ENGLISH**

**CAUTION:** Danger of explosion if battery is incorrectly replaced. Replace only with the same or equivalent type recommended by the equipment manufacturer. Discard used batteries according to manufacturer's instructions.

## **DEUTSCH**

**VORSICHT:** Explosionsgefahr bei unsachgemäßem Austausch der Batterie. Ersatz nur durch denselben oder einen vom Hersteller empfohlenen gleich-wertigen Typ. Entsorgung gebrauchter Batterien nach Angaben des Herstellers.

## **FRENCH**

**ATTENTION:** Il y a danger d'explosion s'il y a un remplacement incorrect de la batterie. Remplacer uniquement avec une batterie du même type ou d'un type équivalent recommandé par le constructeur. Mettre au rebut les batteries usagées conformément aux instructions du fabricant.

## **Attention (for USA Users)**

The product that you have purchased contains a rechargeable battery. The battery is recyclable. At the end of its useful life, under various state and local laws, it may be illegal to dispose of this battery into the municipal waste stream. Check with your local solid waste officials for details in your area for recycling options or proper disposal.

## **About the AC Adapter**

- Use only the AC adapter supplied with your tablet PC. Use of another type of AC adapter will result in malfunction and/or danger.
- Do not use the adapter in a high moisture environment. Never touch the adapter when your hands or feet are wet.
- Allow adequate ventilation around the adapter when using it to operate the device or charge the battery. Do not cover the AC adapter with

paper or other objects that will reduce cooling. Do not use the AC adapter while it is inside a carrying case.

- Connect the adapter to a proper power source. The voltage requirements are found on the product case and/or packaging.
- Do not use the adapter if the cord becomes damaged.
- Do not attempt to service the unit. There are no serviceable parts inside. Replace the unit if it is damaged or exposed to excess moisture.

## About the Modem

### Caution

- Never install telephone wiring during a lightning storm.
- Never install telephone jacks in wet locations unless the jack is specifically designed for wet locations.
- Never touch non-insulated telephone wires or terminals unless the telephone line has been disconnected at the network interface.
- Use caution when installing or modifying telephone lines.
- Avoid using the telephone function (other than a cordless type) during an electrical storm. There may be a remote risk of electric shock from lightning.
- Do not use the telephone function to report a gas leak in the vicinity of the leak.
- Do not use this product near water, for example near a bathtub, wash bowl, kitchen sink or laundry tub, in a wet basement or near a swimming pool.

### Caution (for USA Users)

To reduce the risk of fire, use only No.26 AWG or larger telecommunication line cord.

# On the Use of the RF Device

**NOTE:** The information in this section applies to models with the wireless LAN module.

## USA and Canada Safety Requirements and Notices

**IMPORTANT NOTE:** To comply with FCC RF exposure compliance requirements, the antenna used for this transmitter must be installed to provide a separation distance of at least 20 cm from all persons and must not be co-located or operating in conjunction with any other antenna or transmitter.

## Radio Frequency Interference Requirements and SAR

The FCC with its action in ET Docket 93-62 has adopted a safety standard for human exposure to Radio Frequency (RF) electromagnetic energy emitted by FCC certified equipment. The wireless LAN module meets the Human Exposure limits found in OET Bulletin 65, 2001, and ANSI/IEEE C95.1, 1992. Proper operation of this radio according to the instructions found in this manual will result in exposure substantially below the FCC's recommended limits. The following safety precautions should be observed:

- Do not touch or move antenna while the unit is transmitting or receiving.
- Do not hold any component containing the radio such that the antenna is very close or touching any exposed parts of the body, especially the face or eyes, while transmitting.
- Do not operate the radio or attempt to transmit data unless the antenna is connected; if not, the radio may be damaged.

### Use in specific environments:

- The use of wireless devices in hazardous locations is limited by the constraints posed by the safety directors of such environments.



- The use of wireless devices on airplanes is governed by the Federal Aviation Administration (FAA).
- The use of wireless devices in hospitals is restricted to the limits set forth by each hospital.

### **Antenna use:**

- In order to comply with FCC RF exposure limits, low gain integrated antennas should be located at a minimum distance of 20 cm (8 inches) or more from the body of all persons.
- High-gain, wall-mount, or mast-mount antennas are designed to be professionally installed and should be located at a minimum distance of 30 cm (12 inches) or more from the body of all persons. Please contact your professional installer, VAR, or antenna manufacturer for proper installation requirements.

### **Explosive Device Proximity Warning**

**WARNING:** Do not operate a portable transmitter (such as a wireless network device) near unshielded blasting caps or in an explosive environment unless the device has been modified to be qualified for such use.

### **Antenna Warning**

**WARNING:** To comply with the FCC and ANSI C95.1 RF exposure limits, it is recommended that the antenna for this device be installed so as to provide a separation distance of at least 20 cm (8 inches) from all persons and that the antenna must not be co-located or operating in conjunction with any other antenna or radio transmitter. It is recommended that the user limit exposure time if the antenna is positioned closer than 20 cm (8 inches).

### **Use on Aircraft Caution**

**CAUTION:** Regulations of the FCC and FAA prohibit airborne operation of radio-frequency wireless devices because their signals could interfere with critical aircraft instruments.

## EMC Requirements

This device uses, generates and radiates radio frequency energy. The radio frequency energy produced by this device is well below the maximum exposure allowed by the Federal Communications Commission (FCC).

This device complies with the limits for a Class B digital device pursuant to Part 15 subpart C of the FCC Rules and Regulations. Operation is subject to the following two conditions:

- (1) This device may not cause harmful interference.
- (2) This device must accept any interference received, including interference that may cause undesired operation.

The FCC limits are designed to provide reasonable protection against harmful interference when the equipment is installed and used in accordance with the instruction manual and operated in a commercial environment. However, there is no guarantee that interference will not occur in a particular commercial installation, or if operated in a residential area.

If harmful interference with radio or television reception occurs when the device is turned on, the user must correct the situation at the user's own expense. The user is encouraged to try one or more of the following corrective measures:

- Reorient or relocate the receiving antenna.
- Increase the separation between the equipment and receiver.
- Connect the equipment into an outlet on a circuit different from that to which the receiver is connected.
- Consult the dealer or an experienced radio/TV technician for help.

**CAUTION:** The Part 15 radio device operates on a non-interference basis with other devices operating at this frequency. Any changes or modification to said product not expressly approved by the manufacturer could void the user's authority to operate this device.

## Canada Radio Frequency Interference Requirements

To prevent radio interference to the licensed service, this device is intended to be operated indoors and away from windows to provide maximum

shielding. Equipment (or its transmit antenna) that is installed outdoors is subject to licensing.

Pour empêcher que cet appareil cause du brouillage au service faisant l'objet d'une licence, il doit être utilisé à l'intérieur et devrait être placé loin des fenêtres afin de fournir un écran de blindage maximal. Si le matériel (ou son antenne d'émission) est installé à l'extérieur, il doit faire l'objet d'une licence.

## European Union CE Marking and Compliance Notices

### Statements of Compliance

#### English

This product follows the provisions of the European Directive 1999/5/EC.

#### Danish

Dette produkt er i overensstemmelse med det europæiske direktiv 1999/5/EC.

#### Dutch

Dit product is in navolging van de bepalingen van Europees Directief 1999/5/EC.

#### Finnish

Tämä tuote noudattaa EU-direktiivin 1999/5/EC määräyksiä.

#### French

Ce produit est conforme aux exigences de la Directive Européenne 1999/5/EC.

#### German

Dieses Produkt entspricht den Bestimmungen der Europäischen Richtlinie 1999/5/EC.

#### Greek

Το προϊόν αυτό πληροί τις προβλέψεις της Ευρωπαϊκής Οδηγίας 1999/5/EC.

**Icelandic**

Pessi vara stenst reglugerð Evrópska Efnahags Bandalagsins númer 1999/5/EC.

**Italian**

Questo prodotto è conforme alla Direttiva Europea 1999/5/EC.

**Norwegian**

Dette produktet er i henhold til bestemmelsene i det europeiske direktivet 1999/5/EC.

**Portuguese**

Este produto cumpre com as normas da Diretiva Européia 1999/5/EC.

**Spanish**

Este producto cumple con las normas del Directivo Europeo 1999/5/EC.

**Swedish**

Denna produkt har tillverkats i enlighet med EG-direktiv 1999/5/EC.

## Local Restrictions of 802.11a/g/n Radio Usage

**CAUTION:** Due to the fact that the frequencies used by 802.11a/g/n wireless LAN devices may not yet be harmonized in all countries, 802.11a/g/n products are designed for use only in specific countries or regions, and is not allowed to be operated in countries or regions other than those of designated use. As a user of these products, you are responsible for ensuring that the products are used only in the countries or regions for which they were intended and for verifying that they are configured with the correct selection of frequency and channel for the country or region of use. Any deviation from permissible settings and restrictions in the country or region of use could be an infringement of local law and may be punished as such.

The European variant is intended for use throughout the European Economic Area. However, authorization for use is further restricted in particular countries or regions within countries, as follows:

**General**

European standards dictate maximum radiated transmit power of 100 mW Effective Isotropic Radiated Power (EIRP) and the frequency range 2400 – 2483.5 MHz.

## Belgium and the Netherlands

In Belgium and the Netherlands, the product may not be used outdoors. See the instructions next under the heading "Turning Off the Wireless LAN Radio."

## France

### Departments in Which the Wireless LAN Module Can Be Used (Indoors Only)

The wireless LAN module can currently be used indoors only in the following 38 departments of mainland France. Please turn off your wireless LAN radio when operating the device in areas/places other than the 38 departments listed:

01	Ain Orientales	36	Indre	66	Pyrénées
02	Aisne	37	Indre et Loire	67	Bas Rhin
03	Allier	41	Loir et Cher	68	Haut Rhin
05	Hautes Alpes	42	Loire	70	Haute Saône
08	Ardennes	45	Loiret	71	Saône et Loire
09	Ariège	50	Manche	75	Paris
11	Aude	55	Meuse	82	Tarn et Garonne
12	Aveyron	58	Nièvre	84	Vaucluse
16	Charente	59	Nord	88	Vosges
24	Dordogne	60	Oise	89	Yonne
25	Doubs	61	Orne	90	Territoire de Belfort
26	Drôme	63	Puy du Dôme	94	Val de Marne
32	Gers	64	Pyrénées Atlantique		

Departments in Which the Wireless LAN Module's Maximum EIRP Not Shown in the Previous Table

Frequency Ranges (MHz)	Indoors	Outdoors
2400 – 2446.5	10 mW	Not permitted
2446.5 – 2483.5	100 mW	100 mW on private property with Ministry of Defense approval

## Turning Off the Wireless LAN Radio

**NOTE:** Turning the wireless LAN radio off is not the same as disabling the wireless LAN card. It is not necessary to disable the card to meet the regulatory requirements.

While operating the tablet PC in those French departments that do not allow use of the wireless LAN equipment, the user of the equipment must turn off the wireless LAN radio in order to comply with local regulations (see Chapter 2 for more information).