

## **IPPC-8151S Series**

**15" XGA TFT LCD Celeron M  
Fanless Industrial Panel PC with  
Stainless Steel Chassis**

**User Manual**

## **Copyright**

The documentation and the software included with this product are copyrighted 2009 by Advantech Co., Ltd. All rights are reserved. Advantech Co., Ltd. reserves the right to make improvements in the products described in this manual at any time without notice. No part of this manual may be reproduced, copied, translated or transmitted in any form or by any means without the prior written permission of Advantech Co., Ltd. Information provided in this manual is intended to be accurate and reliable. However, Advantech Co., Ltd. assumes no responsibility for its use, nor for any infringements of the rights of third parties, which may result from its use.

## **Acknowledgements**

Intel and Pentium are trademarks of Intel Corporation.

Microsoft Windows and MS-DOS are registered trademarks of Microsoft Corp.

All other product names or trademarks are properties of their respective owners.

Part No. 2003815100

1st Edition

Printed in Taiwan

June 2009

## **Product Warranty (2 years)**

Advantech warrants to you, the original purchaser, that each of its products will be free from defects in materials and workmanship for two years from the date of purchase.

This warranty does not apply to any products which have been repaired or altered by persons other than repair personnel authorized by Advantech, or which have been subject to misuse, abuse, accident or improper installation. Advantech assumes no liability under the terms of this warranty as a consequence of such events.

Because of Advantech's high quality-control standards and rigorous testing, most of our customers never need to use our repair service. If an Advantech product is defective, it will be repaired or replaced at no charge during the warranty period. For out-of-warranty repairs, you will be billed according to the cost of replacement materials, service time and freight. Please consult your dealer for more details.

If you think you have a defective product, follow these steps:

1. Collect all the information about the problem encountered. (For example, CPU speed, Advantech products used, other hardware and software used, etc.) Note anything abnormal and list any onscreen messages you get when the problem occurs.
2. Call your dealer and describe the problem. Please have your manual, product, and any helpful information readily available.
3. If your product is diagnosed as defective, obtain an RMA (return merchandise authorization) number from your dealer. This allows us to process your return more quickly.
4. Carefully pack the defective product, a fully-completed Repair and Replacement Order Card and a photocopy proof of purchase date (such as your sales receipt) in a shippable container. A product returned without proof of the purchase date is not eligible for warranty service.
5. Write the RMA number visibly on the outside of the package and ship it prepaid to your dealer.

## **Declaration of Conformity**

### **CE**

This product has passed the CE test for environmental specifications. Test conditions for passing included the equipment being operated within an industrial enclosure. In order to protect the product from being damaged by ESD (Electrostatic Discharge) and EMI leakage, we strongly recommend the use of CE-compliant industrial enclosure products.

### **FCC Class A**

Note: This equipment has been tested and found to comply with the limits for a Class A digital device, pursuant to part 15 of the FCC Rules. These limits are designed to provide reasonable protection against harmful interference when the equipment is operated in a commercial environment. This equipment generates, uses, and can radiate radio frequency energy and, if not installed and used in accordance with the instruction manual, may cause harmful interference to radio communications. Operation of this equipment in a residential area is likely to cause harmful interference in which case the user will be required to correct the interference at his own expense.

## **Technical Support and Assistance**

- Step 1. Visit the Advantech web site at **[www.advantech.com/support](http://www.advantech.com/support)** where you can find the latest information about the product.
- Step 2. Contact your distributor, sales representative, or Advantech's customer service center for technical support if you need additional assistance. Please have the following information ready before you call:
  - Product name and serial number
  - Description of your peripheral attachments
  - Description of your software (OS, version, software, etc.)
  - A complete description of the problem
  - The exact wording of any error messages

## **Safety Instructions**

1. Read these safety instructions carefully.
2. Keep this User's Manual for later reference.
3. Disconnect this equipment from any AC outlet before cleaning. Use a damp cloth. Do not use liquid or spray detergents for cleaning.
4. For plug-in equipment, the power outlet socket must be located near the equipment and must be easily accessible.
5. Keep this equipment away from humidity.
6. Put this equipment on a reliable surface during installation. Dropping it or letting it fall may cause damage.
7. The openings on the enclosure are for air convection. Protect the equipment from overheating. **DO NOT COVER THE OPENINGS.**
8. Make sure the voltage of the power source is correct before connecting the equipment to the power outlet.
9. Position the power cord so that people cannot step on it. Do not place anything over the power cord.
10. All cautions and warnings on the equipment should be noted.
11. If the equipment is not used for a long time, disconnect it from the power source to avoid damage by transient overvoltage.
12. Never pour any liquid into an opening. This may cause fire or electrical shock.
13. Never open the equipment. For safety reasons, the equipment should be opened only by qualified service personnel.
14. If one of the following situations arises, get the equipment checked by service personnel:
  - a. The power cord or plug is damaged.
  - b. Liquid has penetrated into the equipment.
  - c. The equipment has been exposed to moisture.
  - d. The equipment does not work well, or you cannot get it to work according to the user's manual.
  - e. The equipment has been dropped and damaged.
  - f. The equipment has obvious signs of breakage.

15. DO NOT LEAVE THIS EQUIPMENT IN AN ENVIRONMENT WHERE THE STORAGE TEMPERATURE MAY GO BELOW -40° C OR ABOVE 85° C. THIS COULD DAMAGE THE EQUIPMENT. THE EQUIPMENT SHOULD BE IN A CONTROLLED ENVIRONMENT.

### **Safety Precaution - Static Electricity**

Follow these simple precautions to protect yourself from harm and the products from damage.

1. To avoid electrical shock, always disconnect the power from your PC chassis before you work on it. Don't touch any components on the CPU card or other cards while the PC is on.
2. Disconnect power before making any configuration changes. The sudden rush of power as you connect a jumper or install a card may damage sensitive electronic components.

# Contents

<b>Chapter 1</b>	<b>General Information .....</b>	<b>2</b>
1.1	Introduction .....	2
1.2	Specifications .....	3
1.2.1	General .....	3
1.2.3	LCD Specifications .....	4
1.3	I/O View .....	4
1.4	Dimensions .....	5
<b>Chapter 2</b>	<b>System Setup.....</b>	<b>8</b>
2.2	Stand Kit.....	9
2.3	VESA Arm Kit.....	9
2.4	Install Panel Mount .....	10
2.5	Installing I/O Cables.....	10
2.6	Install a 2.5" SATA HDD .....	10
2.7	Installing a PCI Expansion Card .....	11
2.8	Installing a Power Connector .....	11
<b>Chapter 3</b>	<b>I/O Connector &amp; Setting Mode .....</b>	<b>14</b>
3.1	IPPC-8151S.....	14
3.1.1	COM1,COM3,COM4 : Serial port RS232 .....	17
<b>Chapter 4</b>	<b>Software Configuration .....</b>	<b>20</b>
4.1	Overview .....	20
4.2	Utilities and Drivers .....	20
4.2.1	Touchscreen Gesture Introduction .....	22
4.2.2	Touch Gesture Utility .....	22
<b>Appendix A</b>	<b>WDT Programming .....</b>	<b>26</b>
A.1	Overview .....	26
A.2	Watchdog Timer Programming.....	27
	Table A.1: Watchdog Runtime Registers .....	27
A.3	Example Programs .....	28





## General Information

Sections include:

- Introduction
- Specifications
- Dimensions

# Chapter 1 General Information

## 1.1 Introduction

---

The IPPC-8151S is designed with a fully sealed stainless steel enclosure and uses a special tapered & food safe rubber seal between the bezel and the touchscreen. This allows it to satisfy the stringent standards required in food processing, clinical, chemical or pharmaceutical laboratories. Its fully enclosed design without ventilation slots and external fans makes its completely protected against splashed water, achieving a NEMA4 (IP66) grade of protection.

### **IP66 Grade Protection**

The IP66 rating guarantees waterproof and dustproof protection, ensuring reliable operation in any hazardous environment. Front model to support front IP66 protection grade. All-around model supports IP66 protection grade for all sides including I/O

### **Anti-corrosive Chassis with Chemical Resistant Touchscreen**

Stainless steel chassis' are a great fit for many industrial applications due to their ability to minimize contamination and maintain strict hygienic requirements. 316L stainless steel is more resistant to corrosion than 304, and IP66 protection provides waterproof protection, making them easy to clean or disinfect even with high pressure water. Furthermore the dust-proof capabilities make them exceptionally suitable for applications in hazardous environments. The FDA Food-Standard Sealing Materials meet high hygienic requirements and the touchscreen is resistant to chemical, detergents and disinfectants.

### **High Performance, Fanless Design**

IPPC-8151S is equipped with a 15" LCD screen and a bright and sharp display. The embedded Intel Celeron M 1GHz, 1MB L2 cache and 1GB DDR2 memory satisfy most application computing needs. The fanless design extends operation life, with enhanced anti-shock and anti-vibration properties suitable for harsh environments. Furthermore, with one CompactFlash slot, one PCI expansion and one SATA HDD, IPPC-8151S provides flexibility and meets high capacity demands.

## 1.2 Specifications

---

### 1.2.1 General

**Dimensions (W x H x D):**

**Front Panel:** 400 x 313.6 x 91.24 mm

**Control Box:** 385.3 x 255.3 x 66/81.2 mm

**Cut out Dimensions:** 388 x 301.5 mm

**Weight:** 13 kg (28 lb)

**Power Supply:** 85W

**Input Voltage:** 10~30Vdc

**Output Voltage:** +3.3V@8A,+5V@10A,+12V@4A,+5Vsb@0.75A,  
-12V@1A

**Disk Drive Housing:** Supports 1 x 2.5"SATA HDD, 1 x CompactFlash

### 1.2.2 System Specifications

**CPU:** Intel Celeron M Yonah 423 1.06GHz w/ 1M L2 cache

**BIOS:** Award 4MB

**North Bridge:** 945GME

**South Bridge:** ICH7M-DH

**Memory:** SO-DIMM 200pin DDR2 533MHz, Dual Channel, Default 1GB x 1, Up to 4G

**Storage:** Support 1 x 2.5" SATA and 1 x CF Card Slot (Type II)

**Ethernet Ports:** 10/100/1000 Base-T x 2 (Realtek RTK8111B)

**Serial Ports:** RS-232 x 3 (COM1, COM3, COM4)

**I/O Ports:** VGA x 1, USB2.0 x 4, PS/2 Keyboard x1, PS/2 Mouse x 1, Mic-in, Line-in, Line-out

**PCI Bus Expansion Slot:** 1 x PCI expansion slot

**Watchdog Timer:** Super I/O SMSC,SCH3114, Interval 1sec

### 1.2.3 LCD Specifications

**Backlight Life:** 50,000 hrs

**Contrast Ratio:** 400:1

**Display Size:** 15"

**Display Type:** XGA TFT LCD

**Luminance:** 350 cd/m<sup>2</sup>

**Max. Colors:** 262,144

**Max. Resolution:** 1024 x 768

**Viewing Angle (H/V°):** 120/100

### 1.2.4 Touchscreen Specifications

**Lifespan:** 10 millions times touch at single point

**Light Transmission:** >80%

**Type:** Analog resistive 5-wire

### 1.2.5 Environmental

**Humidity:** 5 ~ 85% @ 40° C (non-condensing)

**Ingress Protection on Front Panel:** NEMA 4X / IP66

**Operating Temperature:** 0 ~ 50° C (32 ~ 122° F)

**Storage Temperature:** -20 ~ 60° C (-4 ~ 140° F)

**Vibration Protection:** 5 ~ 500 Hz, 1Grms random vibration

## 1.3 I/O View

---

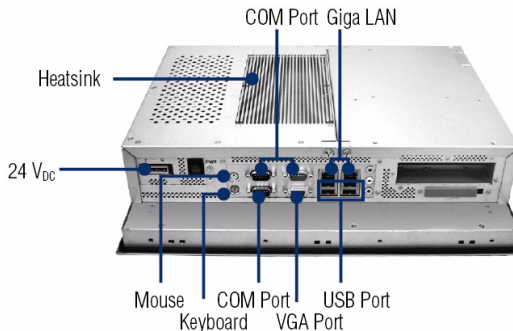

# 1.4 Dimensions

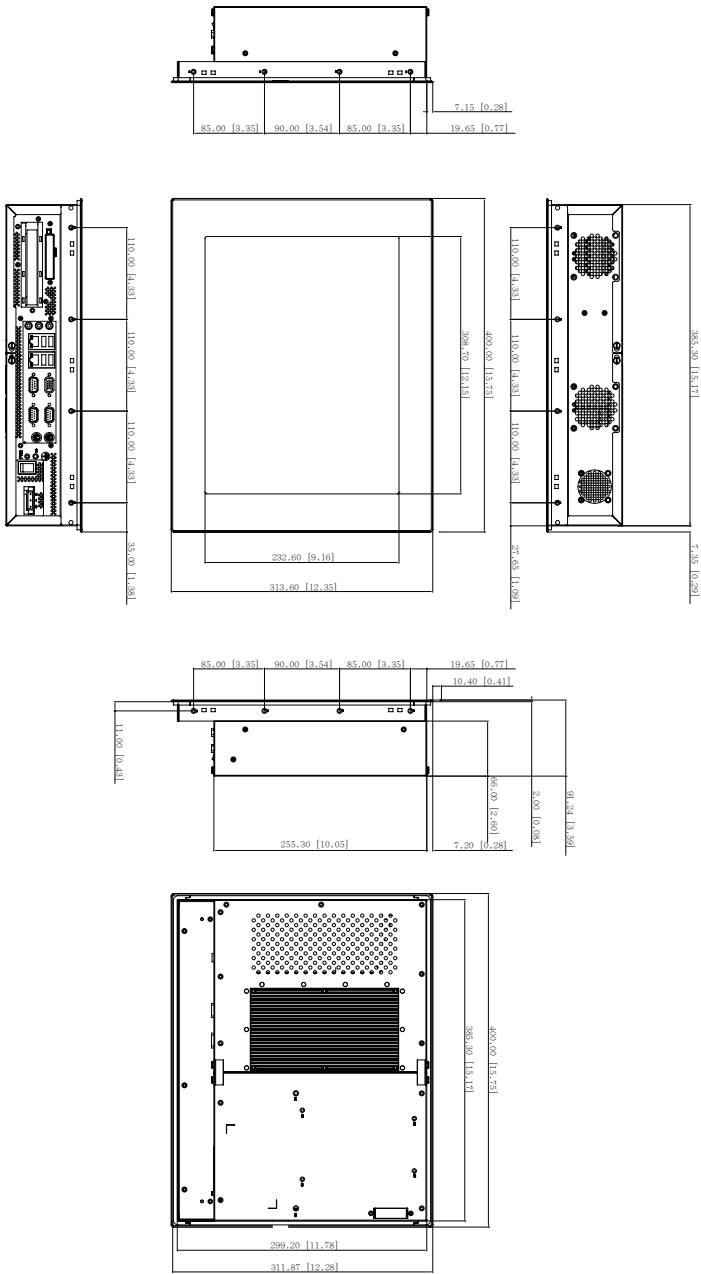



## **System Setup**

Sections include:

- Enclosure Kit
- Desktop Kit
- VESA Arm Kit
- Panel Mounting
- Installing I/O Cables
- Installing a 2.5" SATA HDD
- Installing a PCI Expansion Card
- Installing a Power Connector

# Chapter 2 System Setup

## 2.1 Enclosure Kit

---

With IPPC-8151S enclosure kit (P/N: IPPC-8151S-EMKE), IPPC-8151S can provide all-around IP66 waterproof and dustproof protection. Please follow the instruction below to make sure IP66 protection.

1. Put IPPC-8151S into the enclosure kit
2. Use the fixture to make sure IPPC-8151S is closed tightly with the enclosure kit. Please also use the pad to avoid the scratch on surface while screwing. The surface of the front panel and the enclosure kit should be in the horizon line.  
*Note: The fixture can be bought from a hardware store.*
3. Use the screws from IPPC-8151S-EMKE accessory kit. The Torque value is required minimum 10Kgf.
4. Repeat action 1, 2 and 3 until the four sides of the enclosures kit are closed tightly with screws.

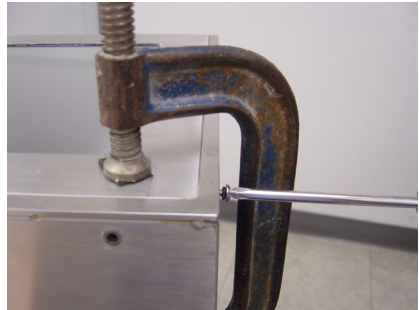



## 2.2 Stand Kit

---

With IPPC-8151S stand kit (P/N: IPPC-8151S-SMKE), IPPC-8151S can stand on the desk, install on the wall or ceiling to meet the environment requirement. The stand kit also supports 360 degree C adjustment for the different view angle. The instruction below shows how to install and use the stand kit.

1. Use the screws from the accessory box of the stand kit to fix the stand kit in both sides.
2. Use the thumb screw to adjust the different view angle or desk, wall or ceiling install.

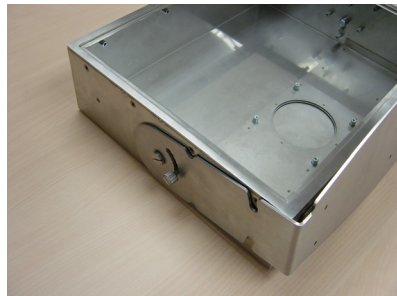

## 2.3 VESA Arm Kit

---

IPPC-8151S arm kit (P/N: IPPC-8151S-AMKE) is to help you to control IPPC-8151S. The instruction below shows how to install arm kit.

1. Use the screws from the accessory kit of arm kit to fix the arms in both sides.



## 2.4 Install Panel Mount

---

1. Take the mounting brackets out of IPPC-8151S accessory box.
2. Attach the four mounting brackets by inserting the screws into the keyhole slots on the cover of the monitor.
3. Use the screws to secure the brackets to the cover. Tighten the screws to secure the monitor to the back panel.

## 2.5 Installing I/O Cables

---

Open the cover from the rear and bottom.

Put the cables through the rear hole to the bottom.

Connect the cables through the bottom.

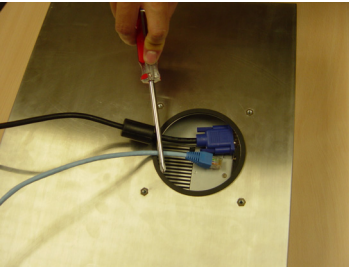

## 2.6 Install a 2.5" SATA HDD

---

IPPC-8151S supports one enhanced Serial Advanced Technology Attachment (SATA) hard disk drive to IPPC-8151S. Please use a wide-temperature industrial hard disk to meet the thermal requirement.

1. Unscrew the back cover and open it.
2. Remove four screws and take off HDD bracket.
3. Insert the HDD into the bracket

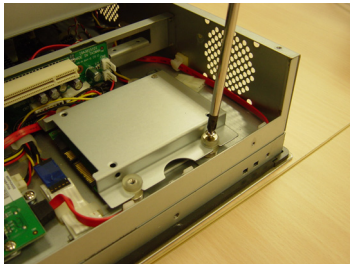

## 2.7 Installing a PCI Expansion Card

---

1. Unscrew the rear cover and open it.
2. Remove the the slot bracket.
3. Insert the add-on card, and close the rear cover

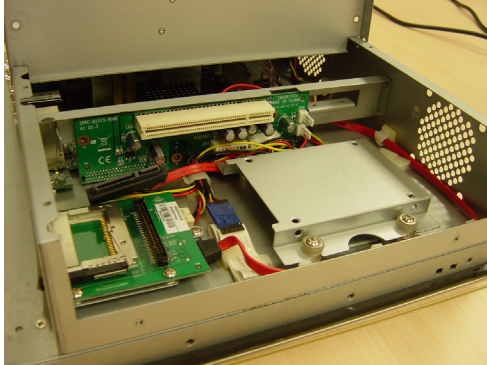

## 2.8 Installing a Power Connector

---

1. Use the tool from the accessory box
2. Press down to open connector hole and insert power wire

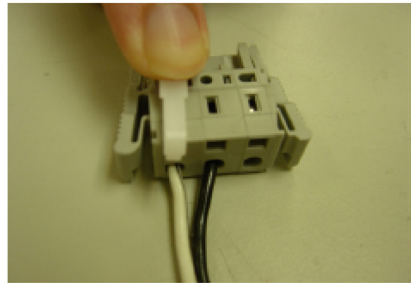
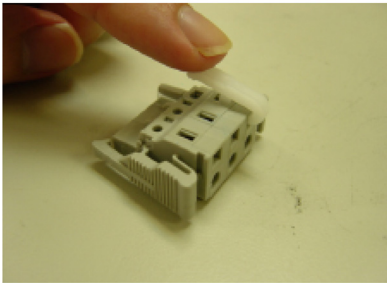



## **Jumper Settings & Connectors**

Sections include:

- Jumpers Settings

# Chapter 3 I/O Connector & Setting Mode

## 3.1 IPPC-8151S

---

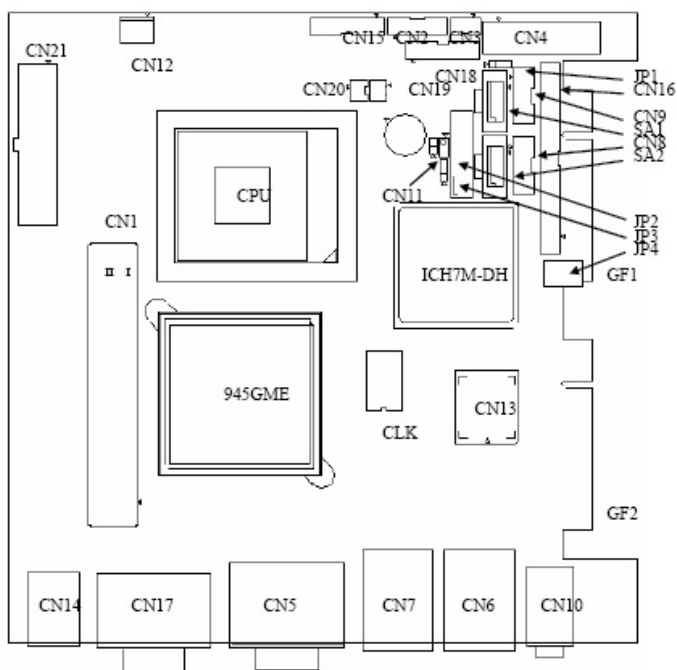

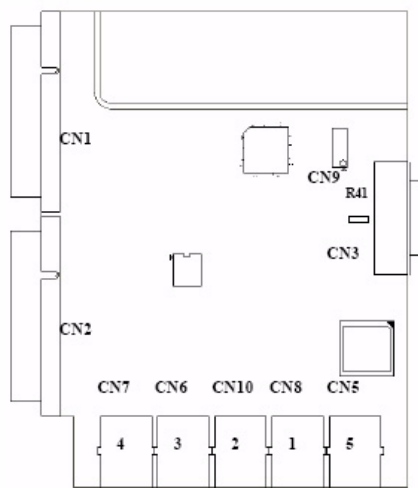

CON. #	Function	Description
CN1	DDR2 SO-DIM*2	Up to 4GB
CN2	INVERTER	TDK TBD266LR-1
CN3	INVERTER VRCtrl	Control inverter brightness by Digital VR DS1804
CN4	LVDS	Dual channels LVDS
CN5	VGA + COM1	VGA + Full DB9 Serial Port COM1
CN6	LAN1 + USB*2	10/100/1000MB Ethernet LAN1 + USB*2
CN7	LAN2 + USB*2	10/100/1000MB Ethernet LAN2 + USB*2
CN8	USB	Inside USB port 1
CN9	USB	Inside USB port 2
CN10	AUDIO	Line-out / Line-in / MIC by ALC650
CN11	BUZZER SELECT	Select internal or external buzzer
CN12	CPU FAN	CPU fan, work @ 12V
CN13	FWH	BIOS FWH, Flash P/N 46LF004B
CN14	PS/2 KB + MS	PS/2 keyboard & mouse
CN15	TOUCH PANEL	8-wired touch panel sensor signals
CN16	IDE	Secondary IDE, Internal IDE 44pin(2mm) connector
CN17	COM3 + COM4	Full DB9 Serial Port COM3 & COM4

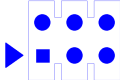
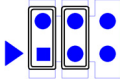
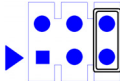
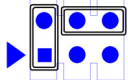
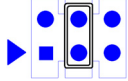
CN18	BOOT Ctrl	Receive external push-button signal / reset / HDDLED
CN19	SNMP I2C BUS	I2C bus for SNMP measure, WINBOND W83782G
CN20	BUZZER OUTPUT	External buzzer output, depend on CN11
CN21	ATX Power-input	Standard ATX Power input
SA1	SATA1	Primary IDE, Master
SA2	SATA2	Primary IDE, Slave
JP1	LVDS PWR Select	For 5V Panel: 1-2 (default) , For 3.3V panel: 2-3
JP2	CLEAR CMOS	Normal: open (default) , Clear CMOS: short
JP3	BATTERY Verify	Normal: 1-2 (default) , just for battery current measure
JP4	LVDS PANEL Sel.	<div style="display: flex; justify-content: space-around;"> <div style="text-align: center;"> <p>1024 * 768 24bit (Default)</p>  <p>800 * 600 24bit</p>  <p><b>VGA only</b></p>  </div> <div style="text-align: center;"> <p><u>1280 * 1024 48bit</u></p>  <p>1600*1200 48bit</p>  </div> </div>



### 3.1.1 COM1,COM3,COM4 : Serial port RS232 Connector Definitions

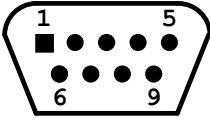

Pin	Signal
1	NDCD
2	NRX
3	NTX
4	NDTR
5	GND
6	NDSR
7	NRTS
8	NCTS
9	NRI



## **Intel Chipset**

Sections include:

- Overview
- Utilities and Drivers
- Dual Display Setting
- Touchscreen Installation & Configuration

# Chapter 4 Software Configuration

## 4.1 Overview

---

In IPPC-8151S , Advantech provides a CD-ROM with utilities and drivers included. Please install the Chipset INF driver, VGA graphics driver, LAN driver, audio driver , Touch Screen driver , Watchdog Timer (WDT) driver sequentially.

## 4.2 Utilities and Drivers

---

The following utilities and drivers are provided with IPPC-8151S. You can also find out the updated description of the utilities and drivers in the ReadMe.txt file on the CD-ROM.

### **Intel Chipset Software Installation Utility**

**Path:** \INF\

**Available for the OS's below,**

- Microsoft Windows 2000
- Microsoft Windows XP

### **VGA Drivers (Intel Graphics Driver)**

**Path:** \VGA\

**Available for the OS's below,**

- Microsoft Windows 2000
- Microsoft Windows XP

### **Intel Network Driver**

**Path:** \Lan\

**Available for the OS's below,**

- Microsoft Windows 2000
- Microsoft Windows XP

**Audio Driver****Path:** \ audio\  
**Available for the OS's below,**

- Microsoft Windows 2000
- Microsoft Windows XP

**Touchscreen Driver****Path:** \Touchscreen Driver\DMC 9000 (Combo)  
**Available for the OS's below,**

- Microsoft Windows 2000
- Microsoft Windows XP and more, on the driver CD-ROM.

**WatchDog Timer Driver****Path:** \WDT\  
**Available for the OS's below:**

- Microsoft Windows 2000
- Microsoft Windows XP

## 4.2.1 Touchscreen Gesture Introduction

Through the touchscreen gesture, the system can disable/enable touch screen functionality, execute hotkeys, execute applications or power on/off the system. Please refer to 4.2.2 for more details.

## 4.2.2 Touch Gesture Utility

### Enabling Touch Gesture:

There are two ways to enable touch gesture utility. One is to click PM icon in right side of task bar and select gesture enable. Two is to go to PenMount control panel and click gesture enable button.

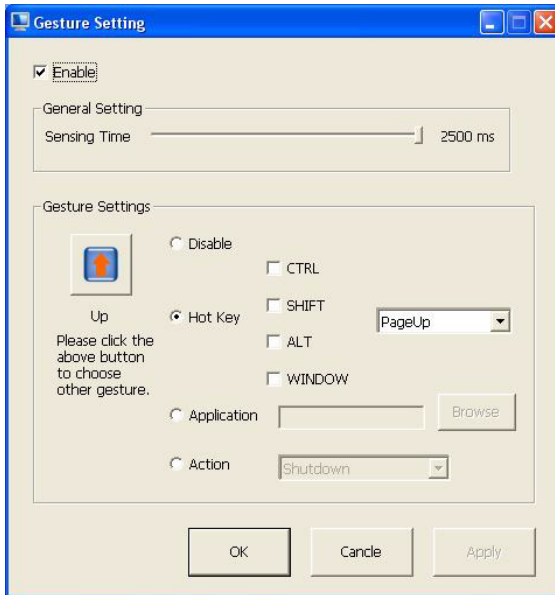
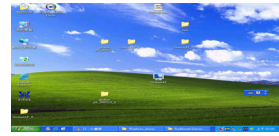
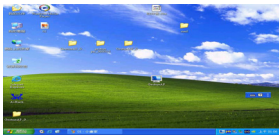

## **Touch Gesture Utility Setup**

Please go to PenMount control panel and click gesture setting button.

A. Enable / Disable Touch Gesture

B. Gesture Sensing Time

The time is to complete one gesture. Value can be set from 200ms to 2500ms.

C. Gesture Setting

The setting for the individual gesture. The blue color means the gesture has been enabled. The gray color means the gesture has been disabled.

D. Disable the individual gesture

E. Hotkey Setting

When the gesture is detected, system will receive the hot key value by the setting.















F. Application Setting

When the gesture is detected, system will execute the application by the setting.

G. Action Setting

When the gesture is detected, system will take action by the setting.

## Gesture Default Setting

	Page Up		Zoom In ([Pad] +)
	Page Down		Zoom Out ([Pad] -)
	Backward (Left Arrow)		Rotate Counter Clockwise (Ctrl + L)
	Forward (Right Arrow)		Rotate Clockwise (Ctrl + K)
	Copy (Ctrl + C)		Open On-Screen Keyboard
	Paste (Ctrl + V)		Save Document (Ctrl + S)
	Undo (Ctrl + Z)		Close Program (Alt + F4)
	Delete		



APPENDIX  
**A**

**Watchdog Timer  
Programming**

# Appendix A WDT Programming

## A.1 Overview

---

The IPPC-8151S cards' watchdog timer can be used to monitor system software operation and take corrective action if the software fails to function after the programmed period. This section describes the operation of the watchdog timer, and how to program it.

The watchdog timer is built into the super I/O controller SMSC SCH3114. It provides the following functions for user programming:

- Can be enabled and disabled by user's program.
- Timer can be set from 1 to 255 seconds or 1 to 255 minutes.
- Generates an interrupt or resets signal if the software fails to reset the timer after time-out.

## A.2 Watchdog Timer Programming

The I/O port address of the watchdog timer is 2E(hex) and 2F(hex), 2E(hex) is the address port. 2F(hex) is the data port. You must first assign the address of register by writing address value into address port 2E(hex), then write/read data to/from the assigned register through data port 2F(hex).

**Table A.1: Watchdog Runtime Registers**

<b>Name</b>	<b>REG OFFSET (HEX)</b>	<b>DESCRIPTION</b>
WDT_TIME_OUT	65	Watch-dog Timeout Bits[6:0] Reserved Bit[7] WDT Time-out Value Units Select = 0 Minutes = 1 Seconds
WDT_VAL	66	Watch-dog Timer Time-out Value Binary coded, units = minutes or seconds, selectable via Bit[7] of WDT_TIME_OUT register (0x65). 0x00 Time out disabled 0x01 Time-out = 1 minute (second) ..... 0xFF Time-out = 255 minutes (seconds)
WDT_CFG	67	Bit[0] Reserved Bit[1] Keyboard Enable =1 WDT is reset upon a Keyboard interrupt. =0 WDT is not affected by Keyboard interrupts. Bit[2] Mouse Enable =1 WDT is reset upon a Mouse interrupt. =0 WDT is not affected by Mouse interrupts. Bit[7:3] Reserved
WDT_CTRL	68	Bit[1] Reserved Bit[2] Force Timeout, =1 Forces WD timeout event; this bit is self-clearing Bit[7:3] Reserved

## A.3 Example Programs

---

### 1. Enable watchdog timer and set 10 seconds of timeout interval

```
;-----  
; enter configuration state  
;-----  
mov  dx, 2Eh  
mov  al, 55h  
out  dx, al  
  
;-----  
; select watchdog registers  
;-----  
mov  al, 7  
mov  dx, 2Eh  
out  dx, al  
mov  dx, 2Fh  
mov  al, 0ah  
out  dx, al  
  
;-----  
; get base address  
;-----  
mov  al, 60h  
mov  dx, 2Eh  
out  dx, al  
mov  dx, 2Fh  
in   al, dx  
mov  ah, al  
  
mov  al, 61h
```

```
mov dx, 2Eh
out dx, al
mov dx, 2Fh
in al, dx
```

; now, AX contains the base address

```
mov bx, ax ; save base address in BX
```

```
;-----
; exit configuration state
```

```
;-----
mov dx, 2Eh
mov al, 0AAh
out dx, al
```

```
;-----
; select WDT pin
```

```
;-----
mov dx, bx
add dx, 47h
mov al, 0Ch
out dx, al
```

```
;-----
; select WDT timeout unit
```

```
;-----
mov dx, bx
add dx, 65h
mov al, 80h ; second
out dx, al
```

```

;-----
; select WDT timeout value
;-----
mov  dx, bx
add  dx, 66h
mov  al, 10      ; 10 seconds
out  dx, al

```

## 2. Enable watchdog timer and set 5 minutes of timeout interval

```

;-----
; enter configuration state
;-----
mov  dx, 2Eh
mov  al, 55h
out  dx, al

;-----
; select watchdog registers
;-----
mov  al, 7
mov  dx, 2Eh
out  dx, al
mov  dx, 2Fh
mov  al, 0ah
out  dx, al

;-----
; get base address
;-----
mov  al, 60h

```

```
mov dx, 2Eh
out dx, al
mov dx, 2Fh
in al, dx
mov ah, al
```

```
mov al, 61h
mov dx, 2Eh
out dx, al
mov dx, 2Fh
in al, dx
```

; now, AX contains the base address

```
mov bx, ax ; save base address in BX
```

```
;-----
; exit configuration state
```

```
;-----
mov dx, 2Eh
mov al, 0AAh
out dx, al
```

```
;-----
; select WDT pin
```

```
;-----
mov dx, bx
add dx, 47h
mov al, 0Ch
out dx, al
```

```

;-----
; select WDT timeout unit
;-----
mov  dx, bx
add  dx, 65h
mov  al, 00h      ; minute
out  dx, al

;-----
; select WDT timeout value
;-----
mov  dx, bx
add  dx, 66h
mov  al, 5        ; 5 minutes
out  dx, al

```

### 3. Enable watchdog timer to be reset upon mouse interrupt

(Note: WDT timeout value must be set before this function can work)

```

;-----
; enter configuration state
;-----
mov  dx, 2Eh
mov  al, 55h
out  dx, al

;-----
; select watchdog registers
;-----
mov  al, 7
mov  dx, 2Eh

```



```

out    dx, al
mov    dx, 2Fh
mov    al, 0ah
out    dx, al

;-----
; get base address
;-----

mov    al, 60h
mov    dx, 2Eh
out    dx, al
mov    dx, 2Fh
in     al, dx
shl   al, 8

mov    al, 61h
mov    dx, 2Eh
out    dx, al
mov    dx, 2Fh
in     al, dx

; now, AX contains the base address

mov    bx, ax ; save base address in BX

;-----
; exit configuration state
;-----

mov    dx, 2Eh
mov    al, 0AAh
out    dx, al

```

```

;-----
; select WDT configuration
;-----
mov  dx, bx
add  dx, 67h
in   al, dx
or   al, 04h      ; reset upon mouse interrupt
out  dx, al

```

#### 4. Enable watchdog timer to be reset upon keyboard interrupt

(Note: WDT timeout value must be set before this function can work)

```

;-----
; enter configuration state
;-----
mov  dx, 2Eh
mov  al, 55h
out  dx, al

;-----
; select watchdog registers
;-----
mov  al, 7
mov  dx, 2Eh
out  dx, al
mov  dx, 2Fh
mov  al, 0ah
out  dx, al

;-----
; get base address

```

```
;-----  
mov  al, 60h  
mov  dx, 2Eh  
out  dx, al  
mov  dx, 2Fh  
in   al, dx  
shl  al, 8
```

```
mov  al, 61h  
mov  dx, 2Eh  
out  dx, al  
mov  dx, 2Fh  
in   al, dx
```

```
; now, AX contains the base address
```

```
mov  bx, ax ; save base address in BX
```

```
;-----  
; exit configuration state  
;-----  
mov  dx, 2Eh  
mov  al, 0AAh  
out  dx, al
```

```
;-----  
; select WDT configuration  
;-----  
mov  dx, bx  
add  dx, 67h  
in   al, dx
```

```
or    al, 02h    ; reset upon keyboard interrupt
out   dx, al
```

## 5. Force timeout

(Note: WDT timeout value must be set before this function can work)

```
;-----
; enter configuration state
;-----
mov   dx, 2Eh
mov   al, 55h
out   dx, al

;-----
; select watchdog registers
;-----
mov   al, 7
mov   dx, 2Eh
out   dx, al
mov   dx, 2Fh
mov   al, 0ah
out   dx, al

;-----
; get base address
;-----
mov   al, 60h
mov   dx, 2Eh
out   dx, al
mov   dx, 2Fh
in    al, dx
```

```
shl    al, 8
```

```
mov    al, 61h
```

```
mov    dx, 2Eh
```

```
out    dx, al
```

```
mov    dx, 2Fh
```

```
in     al, dx
```

```
; now, AX contains the base address
```

```
mov    bx, ax ; save base address in BX
```

```
;-----
```

```
; exit configuration state
```

```
;-----
```

```
mov    dx, 2Eh
```

```
mov    al, 0AAh
```

```
out    dx, al
```

```
;-----
```

```
; Force timeout
```

```
;-----
```

```
mov    dx, bx
```

```
add    dx, 68h
```

```
in     al, dx
```

```
or     al, 04h ; force timeout
```

```
out    dx, al
```

